

Installation Manual

BADUJET® Turbo

Counter Swimming Unit

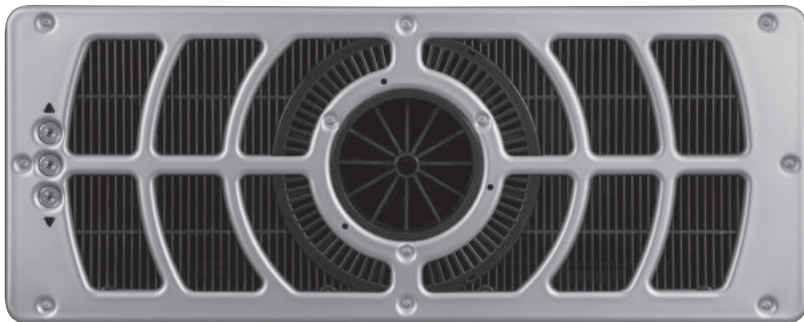

Technical Support:

Address: Speck Pumps
8125 Bayberry Road
Jacksonville, FL. 32256
USA

Hours: (Monday - Friday) 8:00 am to 5:00 pm EST

Toll Free: 800-223-8538

Phone: 904-739-2626

Fax: 904-737-5261

Website: usa.speck-pumps.com

Email: technical.usa@speck-pumps.com

Date of Installation:	
Installed by:	
Serial Number:	
For Service Call:	

Manufactured by Speck Pumps, Jacksonville Florida USA, ©2024 All Rights Reserved.

This document is subject to change without notice.

Table of Contents

1	<i>Important Safety Instructions</i>	4
	Unblockable SwimJet Combination Fitting Manufacturers Warnings	4
	General Safety Instructions.	5
<hr/>		
2	<i>Installation Information</i>	7
	Planning	7
	Receiving Information	8
	Conduit Installation	8
	Concrete or Gunite Installation	9
	Liner and/or Fiberglass Pool Installation	14
	Final Assembly	16
	Electrical - Controller & VFD Installation	17
<hr/>		
3	<i>Service and Maintenance</i>	20
	Stainless Steel	20
	Winterizing	20
<hr/>		
4	<i>Product Specifications</i>	21
	Exploded View	21
	Replacement Parts	22
<hr/>		
5	<i>Product Information</i>	23
	Product Registration	23
	Limited Warranty	23

1 Important Safety Instructions

WARNING: Before Installing this product, read and follow all warning notices and instructions which are included. Failure to follow safety warnings and instructions can result in severe injury, death, or property damage. Call (800) 223-8538 or visit www.usa.speck-pumps.com for additional copies of these instructions.

Unblockable Swim Jet Combination Fitting - Manufacturers Warnings

MUST BE INSTALLED by an experienced and qualified pool industry professional **ONLY**.

Attention Installer: This manual contains important information about installation, operation, and safe use of this product. This information should be given to the owner and/or operator of this equipment. Most states and local codes regulate the construction, installation and operation of pools and spas. It is important to comply with these codes, many which regulate the installation and use of this product.

1. READ, FOLLOW AND UNDERSTAND ALL INSTRUCTIONS AND WARNINGS.

1. **DO NOT** locate this fitting in seating areas or on the back rests for such seating areas.
2. This fitting should be mounted in the vertical pool wall only per manufacturer's instructions. No modifications to the swimjet are permitted.
3. The anti-entrapment cover, when installed, shall not protrude more than 2 in. (51mm) from the finished surface of the pool in which the swimjet is installed.
4. **Service Access:** The use of adhesives or other attachment methods that prevent access to suction piping or swimjet components is **prohibited**.
5. The anti-entrapment cover must be hand-checked for snugness to the jet housing after installation.
6. The anti-entrapment cover and fasteners shall be examined for damage or tampering each operational day.
7. Any missing, broken, or cracked fittings must be replaced before using this product. Only genuine Speck replacement parts may be used.
8. Never exceed the maximum flow rate stated on this product.
9. **WARNING: DO NOT RUN THE SYSTEM DRY OR PERMANENT DAMAGE TO THE PROPELLER MAY OCCUR.**
10. The anti-entrapment cover must be in place when using this product. **DO NOT** use this product if the cover is missing, broken, or loose, and it shall be replaced before bathers are allowed to use the pool.
11. The anti-entrapment cover (part# 5) should be replaced within 10 years from installation date.
12. Installation requires a Phillips screw driver. Hand tighten only. **DO NOT** use electrical or air drills.
13. Consult your physician before exercising with the BADUJET® Turbo.
14. **NOT A TOY! DO NOT** permit children to use this product unless they are closely supervised at all times.
15. **DO NOT** remove any safety alert labels such as **DANGER, WARNING, or CAUTION**. Keep safety alert labels in good condition and replace missing or damaged labels.

Unblockable Swim Jet Combination Fitting - Manufacturers Warnings - continued

16. Stay alert, watch what you are doing and use common sense. **DO NOT** use unit if you are tired and/or exhausted. **DO NOT** use unit while under the influence of drugs, alcohol, or any medications.

17. WARNING: Children should not use spas or hot tubs without adult supervision.

AVERTISSEMENT: Ne pa laisser les enfants utiliser une cuve de relaxation sans surveillance.

18. WARNING: DO NOT use spas or hot tubs unless all suction guards are installed to prevent body and hair entrapment.

19. WARNING: DO NOT permit electric appliances (such as a light, telephone, radio, or television) within 5 ft (1.5 M) of the pool, hot tub, or spa.

20. CAUTION: DO NOT increase pump size; this will increase the flow rate through the system and exceed the maximum flow rate stated on this product.

21. WARNING: The VFD is shipped with the motor cable pre-wired to the drive output to ensure correct motor rotation. **DO NOT ALTER THE WIRING PATTERN! SERIOUS INJURY OR DEATH MAY OCCUR IF THE SYSTEM IS OPERATED IN REVERSE!**

22. WARNING: Parameter set and programming of the VFD are completed at the factory. This ensures that the motor is "tuned" to the VFD, and that motor rotation is correct. Parameters are locked and extended parameters are password protected. **ATTEMPTING TO CHANGE PARAMETERS WILL VOID WARRANTY AND CAN CAUSE SERIOUS INJURY OR DEATH!**

23. WARNING: In the event that the motor cable is replaced at the installation site, **THE INSTALLER MUST VERIFY CORRECT ROTATION OF THE MOTOR AND THAT THE WIRING PATTERN IS CORRECT! SERIOUS INJURY OR DEATH MAY OCCUR IF THE SYSTEM IS OPERATED IN REVERSE!**

IMPROPER INSTALLATION OR USE OF THIS PRODUCT MAY PRESENT A RISK OF HAIR OR BODY ENTRAPMENT AND DROWNING. Install this equipment in accordance with the instructions provided.

As the manufacturer, Speck Pumps-Pool Products, Inc., hereby certifies that their Swim Jet Combination Fitting meets or exceeds the requirements of the Virginia Graeme Baker Pool & Spa Safety Act, VGBA 2017 and ANSI/APSP 16 standards and safety regulations as set forth by the Consumer Products Safety Commission.

SAVE THESE INSTRUCTIONS!

General Safety Instructions

The following guidelines provide information to minimize the risk of injury to users of pools, spas, and hot tubs.

WARNING: TO REDUCE THE RISK OF ENTRAPMENT HAZARD



Pool and spa pumps produce high levels of suction, which can pose extreme danger if a person comes in close proximity to an open pool or spa drain or if a drain cover is loose, cracked, broken or missing. Pool and spa pumps move large volumes of water, which can pose extreme danger if a person's hair comes in close proximity to a drain that is not the proper size for the pump or pumps.

General Safety Instructions - continued

If not an approved single, unblockable outlet, a minimum of two functioning suction outlets per pump must be installed. Suction outlets in the same plane (i.e. floor or wall) must be installed a minimum of three (3) feet (1 meter) apart, as measured from center point to center point. Dual suction fittings shall not be located on seating areas or on the backrest for such seating areas. If any suction outlets are located closer they shall be located on two different planes (i.e. one on the bottom and one on the vertical wall, or one each on two separate vertical walls).

WARNING: *Failure to keep suction outlet components clear of debris, such as leaves, dirt, hair, paper and other material can result in an increased potential for suction entrapment.*

If not a single, unblockable outlet, in the event of one suction outlet being completely blocked, the remaining suction outlets serving the system shall have a flow rating capable of the full flow of the pump(s) or the specific suction system. If in doubt about the rating and/or head loss curve of your system, consult a qualified pool or spa professional and/or your respective equipment manufacturer(s). Also, double check with your local building/health authorities regarding single vs. multiple drain installations, etc.

Regularly inspect all drain covers for cracks, damage and advanced weathering. If a drain cover becomes loose, cracked, damaged, broken or is missing, close the pool or spa immediately, post a notice and keep the pool or spa closed until an appropriate VGBA 2017 certified drain cover is properly installed.

WATER VELOCITY AND FLOW RATES

The maximum water velocity through drain covers is limited by some local regulations, for example some state health departments limit the velocity through public pool drain covers to 1.5 feet per second. This velocity limit is lower than the flow rating provided by the ANSI/APSP 16 certification; therefore local limit applies and must be followed. Never exceed the flow rating listed on the cover even if local code does not provide a velocity limit.

For additional information on proper installation refer to The Association of Pool & Spa Professionals ANSI/APSP-7 Standard and the US Consumer Product Safety Commission Guidelines for Entrapment Hazard.

VGB Compliance - VIRGINIA GRAEME BAKER POOL AND SPA SAFETY ACT

The Virginia Graeme Baker Pool and Spa Safety Act raises certain new requirements on owners and operators of swimming pools and spas.

Pools or spas constructed on or after December 19, 2008, shall utilize:

- (A) No submerged suction outlets, a gravity drainage system with ANSI/APSP compliant cover(s), one or more unblockable outlets; or
- (B) A multiple main drain system without isolation capability with suction outlet covers that meet ANSI/APSP 16 Suction Fittings for Use in Swimming Pools, Wading Pools, Spas, and Hot Tubs and either:
 - (i) A safety vacuum release system (SVRS) meeting ASME/ANSI A112.19.17 Manufactured Safety Vacuum Release Systems (SVRS) for Residential and Commercial Swimming Pool, Spa, Hot Tub, and Wading Pool Suction Systems and/or ASTM F2387 Standard Specification for Manufactured Safety Vacuum Release Systems (SVRS) for Swimming Pools, Spas and Hot Tubs
 - or
 - (ii) A properly designed and tested suction-limiting vent system or
 - (iii) An automatic pump shut-off system.

Pools and spas constructed prior to December 19, 2008, with a single submerged suction outlet shall use a suction outlet cover that meets ANSI/APSP 16 and either:

- (A) A multiple main drain system without isolation capability, or a single (VGBA 2017 compliant) unblockable suction outlet, or
- (B) A safety vacuum release system (SVRS) meeting ASME/ANSI A112.19.17 and/or ASTM F2387, or
- (C) A properly designed and tested suction-limiting vent system, or
- (D) An automatic pump shut-off system, or
- (E) Disabled submerged outlets, or
- (F) Suction outlets shall be reconfigured into return inlets.

General Safety Instructions - continued

For more information about the Virginia Graeme Baker Pool and Spa Safety Act, contact the Consumer Product Safety Commission at (301) 504-7908 or visit www.cpsc.gov.

WARNING: Risk of Electrical Shock or Electrocution

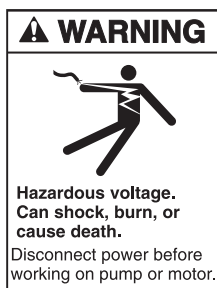

System must be installed by a licensed or certified electrician or a qualified pool serviceman in accordance with the National Electrical Code and all applicable local codes and ordinances. Improper installation will create an electric hazard which could result in death or serious injury to pool users, installers, or others due to electrical shock, and may also cause damage to property.

Always disconnect power to the system at the circuit breaker before servicing the pump. Failure to do so could result in death or serious injury to serviceman, pool users, or others due to electric shock.

2 Installation Information

Planning

The BADUJET Turbo is normally incorporated into the original pool design. It requires **no plumbing**, making it simpler to install compared to our previous swimjet systems.

The BADUJET Turbo requires a clear **unobstructed area** within the swimming pool which is 8 ft wide x 15 ft long x 3 ft deep to work effectively at its full potential. This "swimming envelope" allows enough length for a swimmer to comfortably drift back and swim against the current. **DO NOT** locate the swimjet housing in seating areas or on the back rests for such seating areas.

A vault measuring 24" x 24" x 32" must be constructed behind the Turbo, allowing access to the motor, and providing proper drainage. **Proper drainage is extremely important.** Motor damage due to flooding is not warrantable.

Choosing a Location:

To ensure that there is a clear unobstructed swim lane, it is key to position the swimjet away from surrounding walls, benches, stairs, etc. It is also important to ensure overall symmetry in the pool design, should there be a sun shelf or steps on the side of the pool opposite the jet, for instance, it is imperative that they run the entire length of the back side. See diagram. Be sure to position the jet down the longest possible swim envelope within the pool.

Refer to the diagram (right) for recommended clear area for the BADUJET Turbo.

- IDEAL LOCATION
- || UNFAVORABLE LOCATIONS

Please Note: The BADUJET Turbo is **not recommended** for freeform pools. The BADUJET Turbo requires a straight wall within the pool for installation.

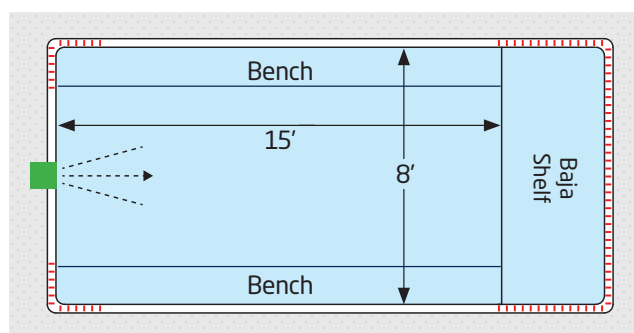
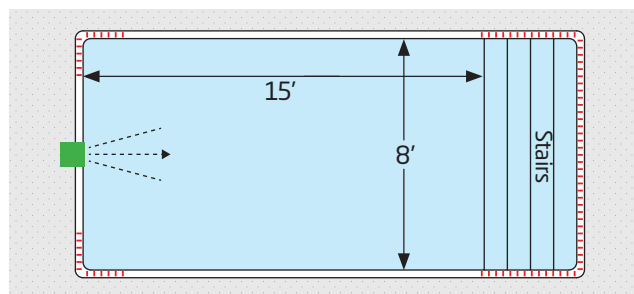

BADUJET Turbo recommended clear area.

**Benches are okay if symmetrical. (A bench on only one side will cause flow failure.)

Receiving Information

1. Upon receipt of the swimjet system, check the cartons for damage. Open each carton and check the motor, jet housing, variable frequency drive (VFD), and control box for concealed damage, such as cracks, dents, or a bent base. If damage is found, contact the shipper or distributor where the product was purchased.

2. Inspect the contents of each carton and verify that all parts are included. (See Image 1)

- A. Flush-mount jet housing (*not shown*)
- B. Plastic or Stainless steel cover
- C. Two-piece clamping ring and suction grate.
- D. Nozzle/Propeller
- E. LED Push Buttons with of 100 ft. cable:
 - Start/Stop (Middle)
 - Increase Speed (Top)
 - Decrease Speed (Bottom)
- F. Magnetic drive motor unit with 80ft. orange VFD cable.
- G. Variable frequency drive NEMA 4X
- H. SPECK BJC-Turbo Control box

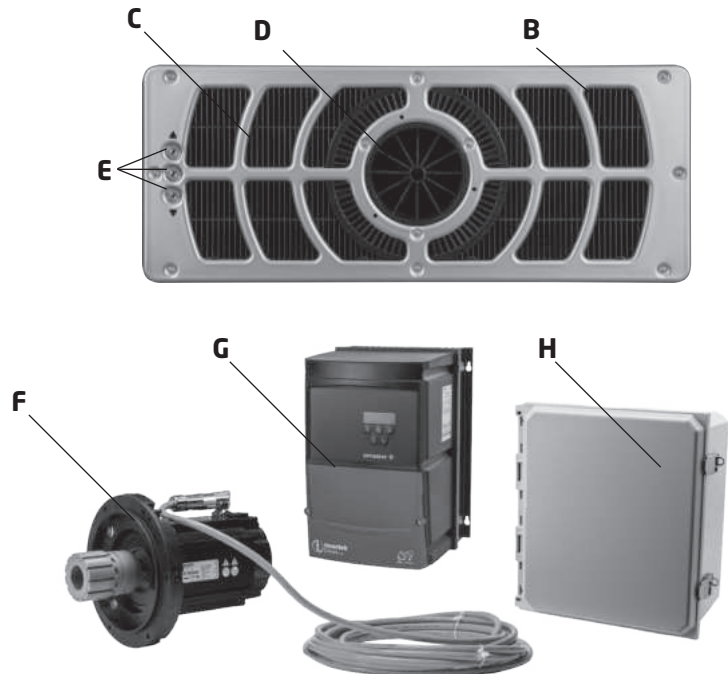

Image 1
BADUJET Turbo System

Conduit Installation

1. Install the protective conduit from the jet housing to control box and VFD location:

- Glue the metric side of the M25 x 1" conduit adapter (*part# 13*) to the port on the rear of the BADUJET Turbo housing. See Image 2. The three (3) push button cables are routed through this opening.
- Glue 1" flexible (liquid-tight) or rigid PVC conduit to the conduit adapter from the above step. Run the conduit to the control box location, **ABOVE THE WATER LINE**.

CAUTION: There is 100 ft of cable for each of the three (3) push buttons included with the BADUJET Turbo. If a longer distance is required to reach the control box, a junction box may be installed above the water line to splice additional cable as needed (24 AWG / 6 Conductor) or a longer cable is available for purchase.

- The orange motor cable must run through a separate 1" conduit. Follow these steps:
 - Remove the orange cable from the VFD by disconnecting the wires labeled U, V, W (Black), the ground wire (yellow/green), and the small brown and white wires from VFD terminals 4 & 5.
 - Remove the 3/4" liquid tight cord grip from the VFD. Do not discard, it will be reused.
 - Install a 1" conduit connector on the VFD in the same location where the cord grip was removed (not included).
 - Run 1" flexible liquid-tight or rigid PVC conduit to the jet housing location, near the motor.
 - Install a 1" x 3/4" female adapter on the end of the conduit near the motor (not included).

Conduit Installation

- Install the liquid tight cord grip from previous step into the female adapter.
- Pull cable from the motor location through conduit back to the VFD.
- Reconnect the wires at the VFD in the same manner before they were removed. **CAUTION: Motor cable wires labeled U, V, & W must be connected to matching labeled terminals! IMPROPER WIRE CONNECTIONS MAY RESULT IN SERIOUS INJURY OR DEATH!**
- Tighten the liquid tight cord grip at the end of the conduit near the motor.
- Install the plug onto the motor. Tighten the collar on the connector until you feel 4-5 "clicks."

CAUTION: There is 80 ft orange VFD motor cable included with the BADUJET Turbo. If a longer distance is required, please contact the factory directly for longer options. This cable **should not** be spliced and extended.

- Review the connection diagram in Figure 1 for an overview of connections between the control box, VFD, and swim jet.

2. Glue the bonding adapter as shown on page 18. Follow steps on that page for bonding the stainless steel cover to the pool structure.



Image 2
BADUJET Turbo - gluing conduit adapter

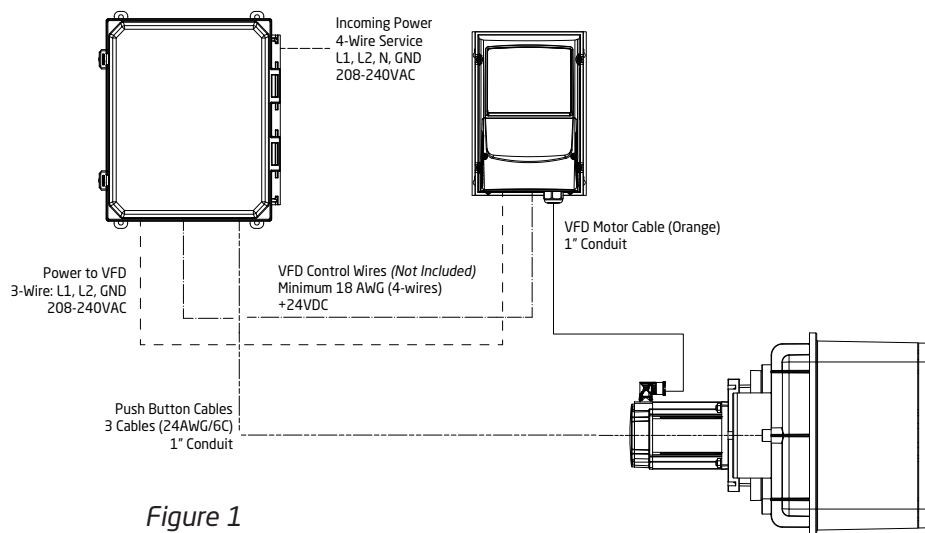

Figure 1

Jet Housing Installation - New Gunite or Concrete Construction

CAUTION: All necessary screws and bolts included with the BADUJET Turbo are stainless steel. **ALL** screw threads and threaded inserts are **METRIC! ONLY METRIC** hardware may be used! All screws should be **HAND TIGHT. DO NOT** use drills or pneumatic tools. **DO NOT** over tighten!

SERVICE ACCESS: The BADUJET Turbo electric motor unit is mounted directly to the rear of the jet housing. A minimum open space of 24" x 24" x 32" is required around the motor unit for ventilation and service access (See Figure 2 & 2A). Smaller open spaces will not allow the motor to cool properly and cause an over-temperature fault at the VFD. The VFD monitors the motor temperature by way of a PTC Thermistor. Drainage must be included at the bottom of this service access vault. SPECK recommends a 24" x 24" opening at the top of the access vault used in combination with a removable access cover.

Jet Housing Installation - New Gunite or Concrete Construction

Figure 2

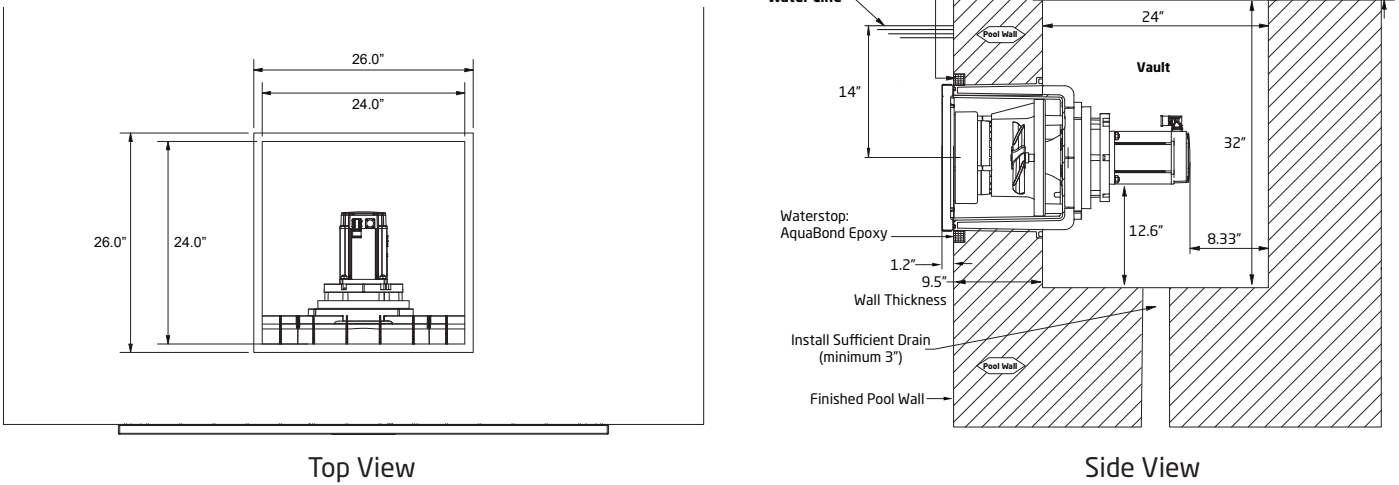

1. Insert the two wooden supports (*part #17*) as shown in Figure 2A. These are temporarily installed to support the housing shape under the weight of gunite/concrete. See Image 3

2. Install the foam strip around the front edge of the jet housing. This strip will be removed after concrete is dry. See Image 3.

3. For Gunite Pools:

- To keep gunite out of the mounting holes and housing, we provide a white gunite cover that should be installed until the pool wall has cured. The cover is held to the housing with four (4) of the 6 x 22 tapping screws (*part #56*). Tape the entire edge around the housing and gunite cover.

- Place the housing between steel rebar, **making sure that "OBEN/UP/HAUT"** is at the top on the rear of the housing (See Figure 3).

CAUTION: The centerline of the housing **MUST** be installed at a depth of 14" below the water line of the finished plaster pool. **JET HOUSING LOCATION IS VERY IMPORTANT!**

- See Image 4 & 5 on following page of the housing location in rebar.

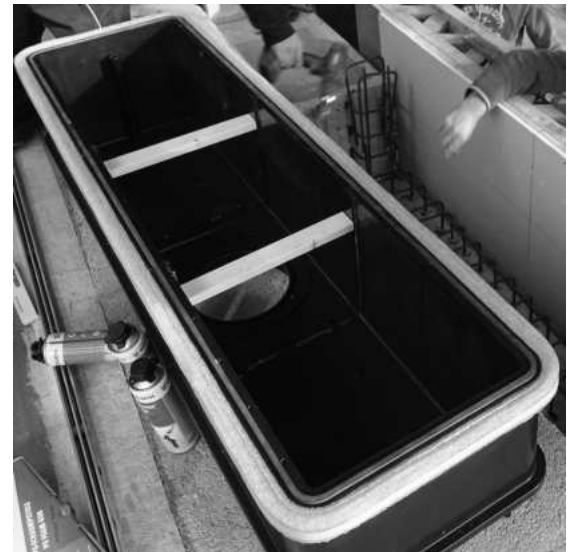
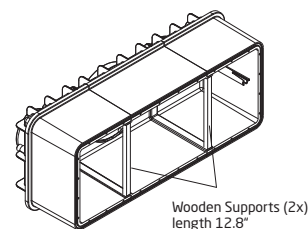
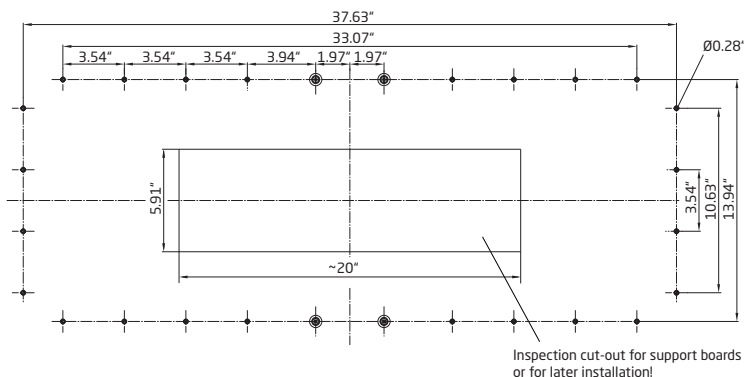

Image 3
BADUJET Turbo - Foam Strip & Wooden Supports

Figure 2A



Jet Housing Installation - New Gunite or Concrete Construction - continued

Figure 3

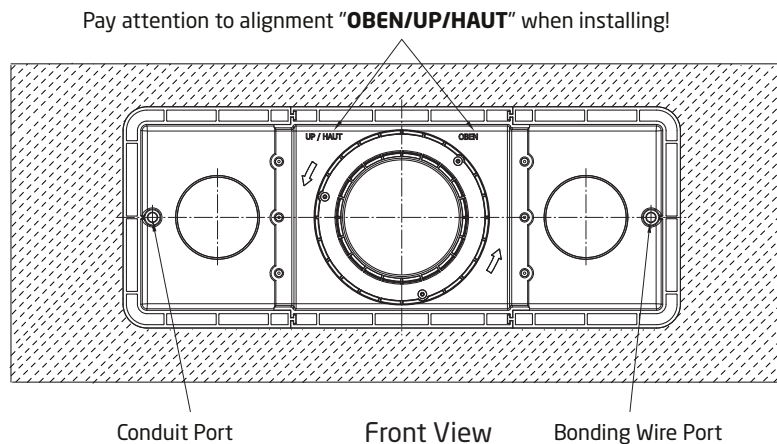

Image 4
BADUJET Turbo - Jet placement in rebar

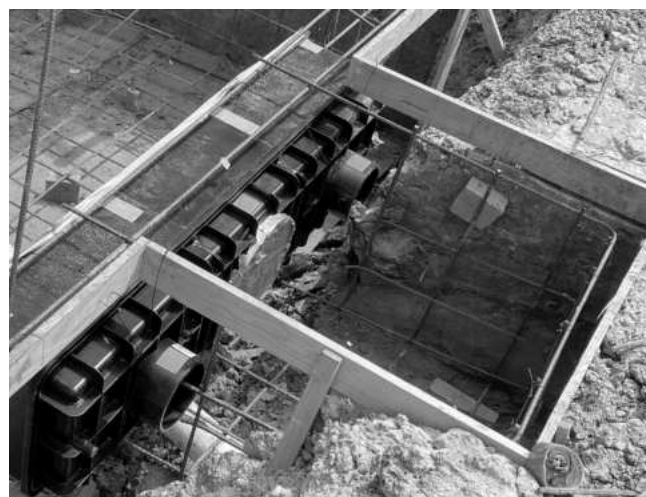

Image 5
BADUJET Turbo - Vault with rebar

4. For Poured Concrete Pools Only:

- Create formwork as shown in Figures 2A. Figure 2A shows the drill pattern for the mounting holes and the optional cut-out for the wooden supports.
- Drill the 28 holes (9/32" drill bit) in the formwork for the inner pool wall per Figure 2. Cut a 39" (W) x 15.5" (H) hole in the formwork for the outer pool wall. **CAUTION: The center of the jet housing *MUST BE* mounted 14" *BELOW* the water line as shown in Figure 2.**
- Insert the round sealing cord (part #16) in the groove around the rear edge of the housing.
- Making sure that **OBEN/UP/HAUT** is at the top of the housing (See Figure 3), place the jet housing between steel rebar with the rear against the hole in the outer wall formwork. Jet housing location is very important!
- Place the inner wall formwork on the front of the jet housing, lining up the pre-drilled holes with the holes in the front of the jet housing.
- Secure the inner pool wall formwork to the jet housing using the 28 (twenty-eight) 6 x 40mm tapping screws (part #19).

Jet Housing Installation - New Gunite or Concrete Construction - continued

5. Shoot Gunite or Pour Concrete:

- **IMPORTANT: Front edge of the jet housing should be flush with the finished pool wall (i.e. after plaster, marcite, etc.).**
- Recheck the location of the jet housing when pouring concrete or shooting gunite. Make sure the housing remains properly aligned and level.
- Once concrete has dried, remove the foam strip from around the front edge of the jet housing. This will expose a groove just over 1" x 1" around the entire edge of the jet housing.
- Use the included AquaBond AE-2200 Anchoing Epoxy to fill the groove around the jet housing. The epoxy cartridges fit in a standard caulk gun. Follow all AquaBond instructions for application and drying time. The epoxy should finish flush with the surrounding concrete.



Image 6
AquaBond AE-2200-250 Anchoing Epoxy

6. Install the 2-part clamping ring (part # 18) based on your pool construction:

NOTE: For simplified winterizing, install the two 2.5" foam strips between the overlapping sections of the clamping ring as shown in the pictures below.

Gunite Wall (no tile or liner):

- A. Connect the two halves of the clamping ring (part #18) together using two (2) 6 x 22mm screws (part #56).
- B. Feed the cables for each LED push button through the three holes on the left side of the suction cover assembly. Press the buttons into place on the suction cover assembly. Use a piece of tape on the end of each cable and mark the three cables:
TOP = INCREASE SPEED
MIDDLE = START/STOP
BOTTOM = DECREASE SPEED
- C. Feed the three cables through the jet housing and previously installed protective conduit to the control box location.
- D. Secure the clamping ring (part #18) assembly to the jet housing using the 28 (twenty-eight) 6 x 40mm screws (part #19).

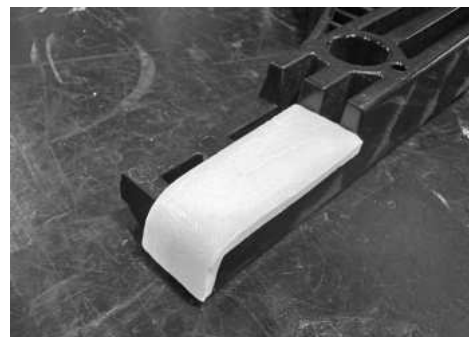

Image 7
Foam Strip Installation

Concrete Pool with Vinyl Liner:

- A. Connect the two halves of the clamping ring (part #18) together using two (2) M6 x 20mm screws (part #56.1). See Figure 4.
- B. Using the suction cover as a template, mark the 28 screw holes and the large rectangular hole (36.61" x 12.91") on the vinyl liner. **NOTE: Ensure that the center line of the cover is 14" BELOW water level.** See Figure 5. Once marked, drill the screw holes and cut the rectangular hole in the vinyl liner.
- C. Feed the cables for each LED push button through the three holes on the left side of the suction cover assembly. Press the buttons into place on the suction cover assembly. Use a piece of tape on the end of each cable and mark the three cables:
TOP = INCREASE SPEED
MIDDLE = START/STOP
BOTTOM = DECREASE SPEED
- D. Insert the gasket (part #11) into the groove around the front of the jet housing. The gasket may be held in place with a drop of super glue.

Jet Housing Installation - New Gunite or Concrete Construction - continued

- E. Install the liner with the holes aligned to the jet housing. Align the suction cover assembly and secure to the housing using the 28 (twenty-eight) 6 x 40mm tapping screws (part #19).

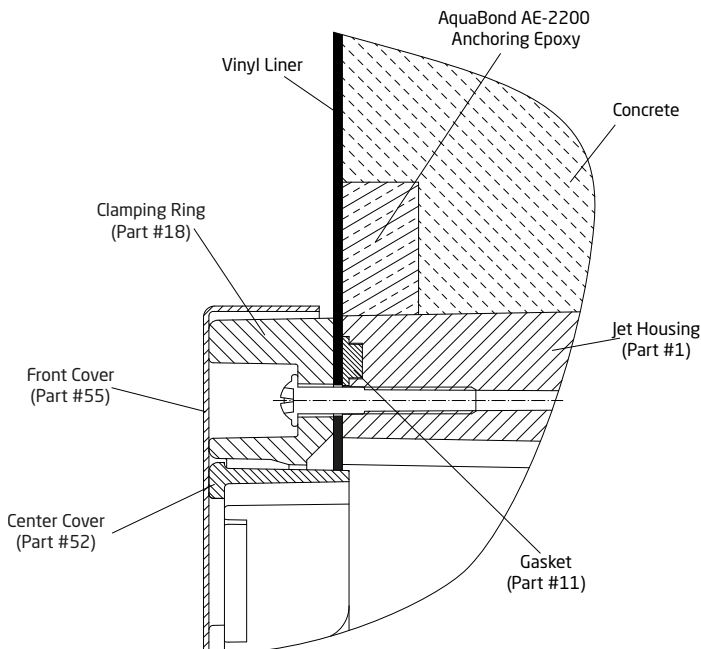

Figure 4

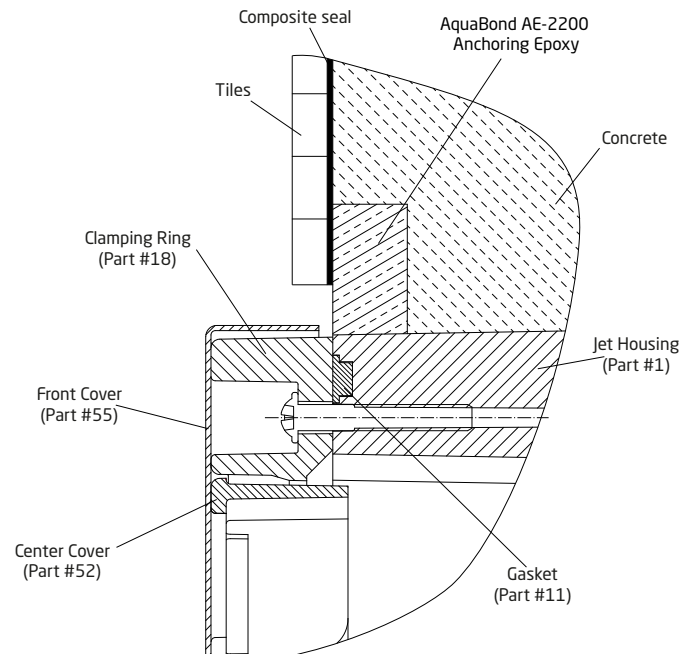

Figure 5

Figure 6

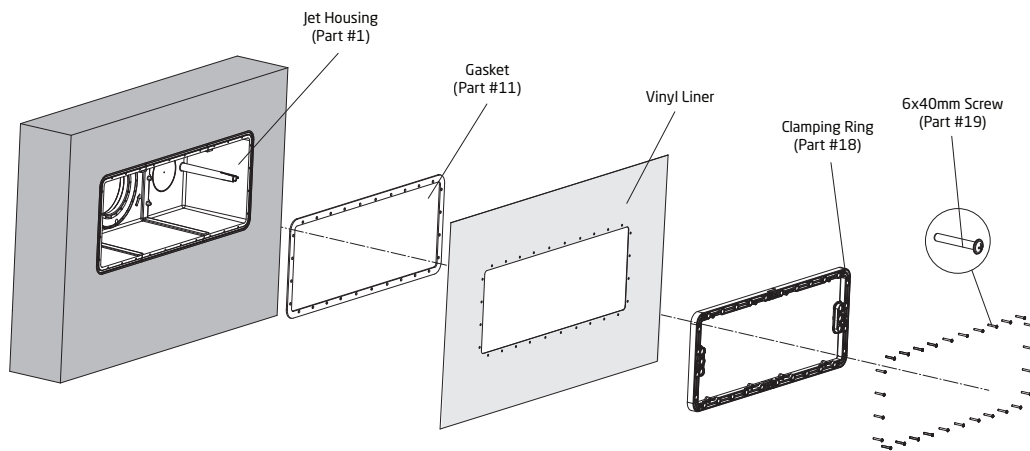
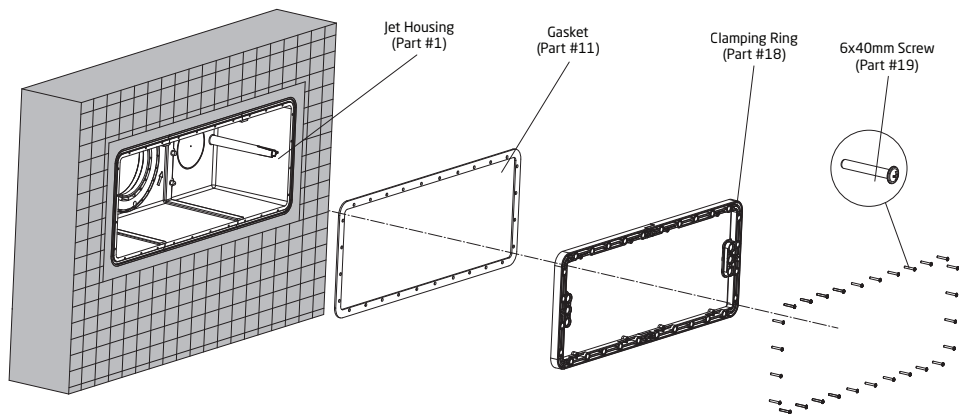

Figure 7



Liner and/or Fiberglass Pool Installation Pool Construction - continued

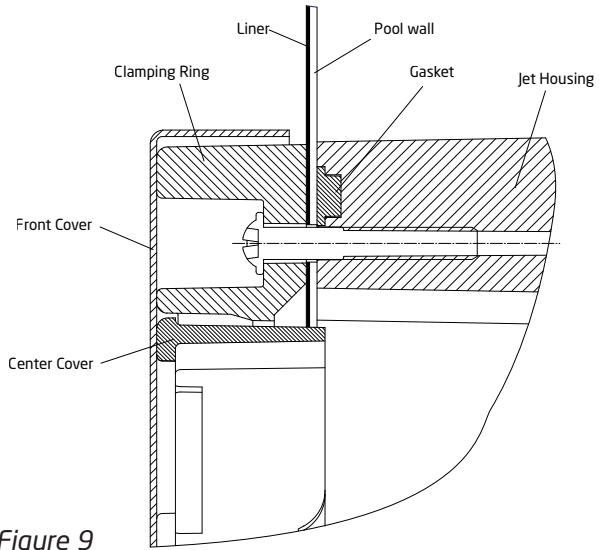
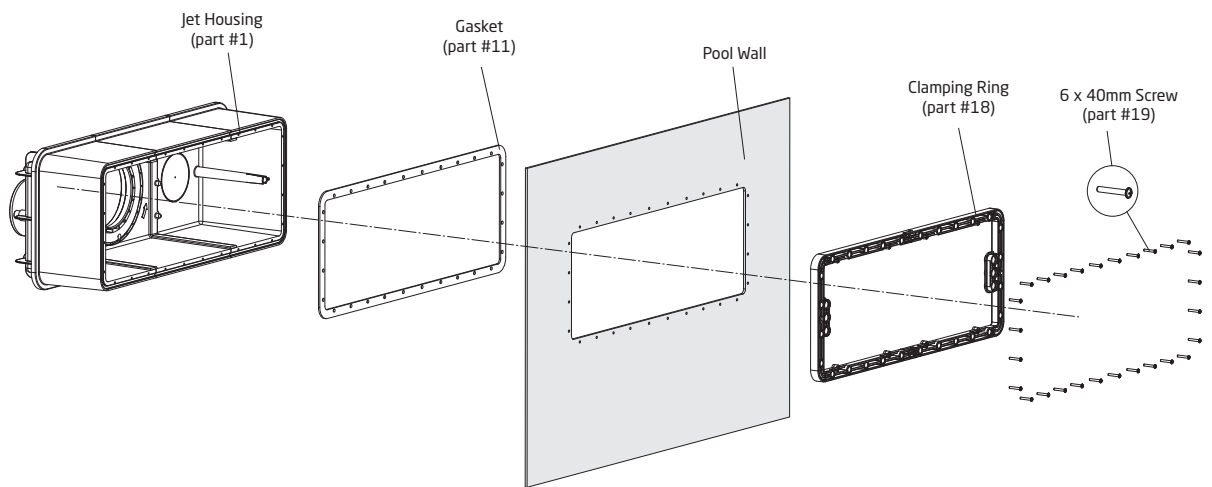

Figure 9

Figure 10



Final Assembly

1. Install the nozzle unit:

- Insert the pre-assembled nozzle unit (*part #4*) into the front of the jet housing through the large hole in the center of the suction cover. Make sure the three pegs align properly with the three holes inside the jet housing.
- Secure the nozzle unit with the three tapping screws (*part #46*). *NOTE: Appropriately sized spacers (part #45) are required for fiberglass or steel pool walls with a wall thickness greater than 3.5mm (1/8") up to 27mm (1-1/16"). The spacer size must be chosen so that the gap between the center cover (part #52) and the nozzle unit (part #4) must not be larger than 8mm (5/16").*
- See below chart for spacer order kits corresponding to various wall thicknesses:

Wall Thickness mm (inches)	Spacer Type	Screw Length (mm)	Order Kit
Up to 3.5mm (1/8")	N/A	40	N/A
Up to 3.5mm (1/8") up to 7mm (1/4")	Washer 3.5	40	N/A
Over to 7mm (1/4") up to 11.5mm (7/16")	Washer 7	50	1
Over to 11.5mm (7/16") up to 14mm (9/16")	C	50	1
Over to 14mm (9/16") up to 17.5mm (11/16")	D	50	1
Over to 17.5mm (11/16") up to 21mm (13/16")	E	60	2
Over to 21mm (13/16") up to 24mm (15/16")	F	60	2
Over to 24mm (15/16") up to 27mm (1-1/16")	G	60	2

2. Secure the two-piece suction grate (*part #5*) to the clamping ring with eight (8) M2 x 20mm screws (*part #56.1*).

3. Install the front cover (*part #55*):

- Remove the two M6 x 20mm screws that were previously installed to connect the two-piece clamping ring (top center and bottom center holes). See Figure 11.
- Place the front cover (*part #55*) over the suction grate (*part #5*), making sure that the holes line up properly.
- Secure the front cover using 8 (eight) M6 x 20mm screws (*part #56.1*), and 3 (three) 6 x 22mm tapping screws.

Figure 11

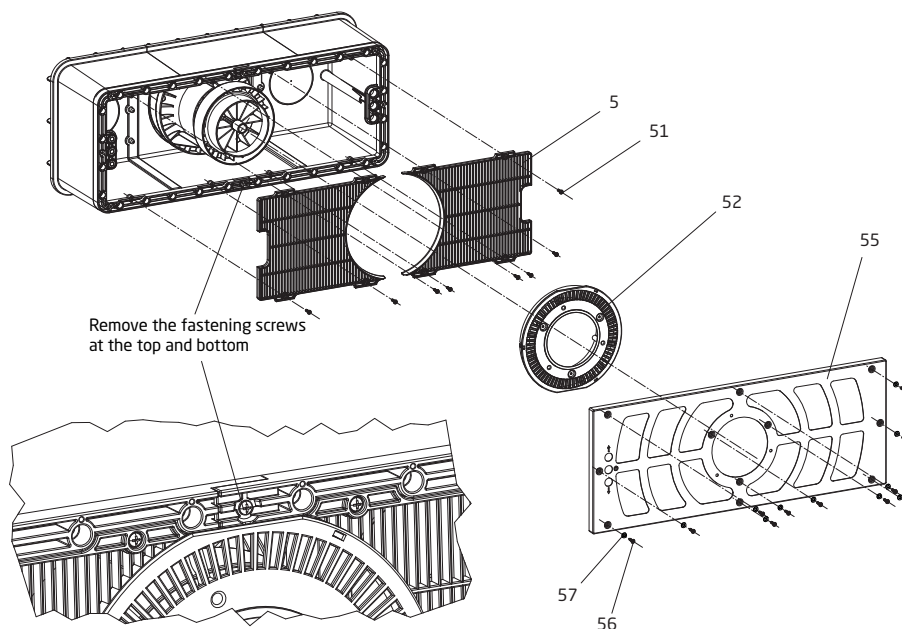

Final Assembly - continued

4. Install the pre-assembled propeller unit:

- Place the 217 x 7mm O-ring (part #36) over the impeller and onto the O-ring seat of the propeller unit (part #3).
- Insert the propeller unit into the large center hole on the rear of the jet housing, making sure the alignment pin is at the 6 o'clock position.
- Secure the propeller unit to the jet housing with 10 (ten) M7 x 48mm tapping screws (part #37).

5. Install the pre-assembled motor unit:

- Align the motor unit (part #2) with the center hole on the rear of the propeller unit. The plug connection should be at the TOP of the motor. **CAUTION: Strong magnetic coupling: keep fingers clear of front of motor unit when installing!**
- Carefully insert the magnet of the motor unit into the propeller unit. The force of the magnetic coupling will pull the motor unit forward!
- Secure the motor unit using the 6 (six) M7 x 48mm tapping screws (part #29). See Figure 12.

Figure 12

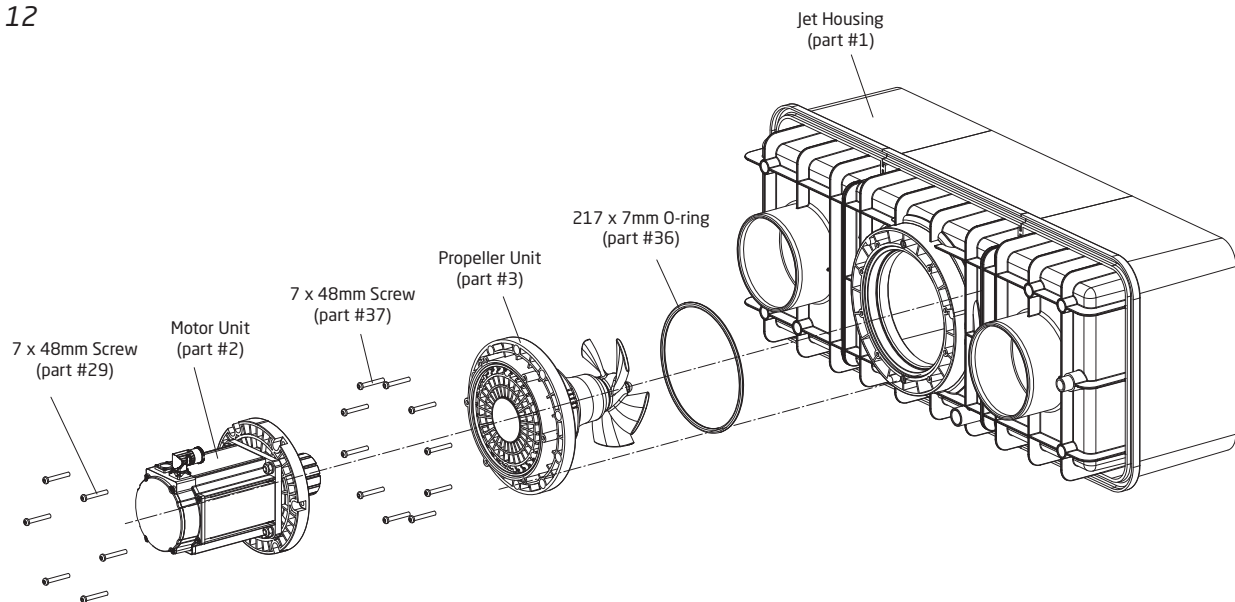

Electrical Installation - Controller, VFD

WARNING: The wiring of the pool motor and control box should be done by a licensed electrician in accordance with all local, state, and federal codes. Be certain that the motor frame and control box are properly grounded. Motor name plate lists voltage, phase, amp draw, and other information as well as wiring connection instructions.

WARNING: The VFD is shipped with the motor cable pre-wired to the drive output to ensure correct motor rotation. **DO NOT ALTER THE WIRING PATTERN! SERIOUS INJURY OR DEATH MAY OCCUR IF THE SYSTEM IS OPERATED IN REVERSE!**

WARNING: Parameter set and programming of the VFD are completed at the factory. This ensures that the motor is "tuned" to the VFD, and that motor rotation is correct. Parameters are locked and extended parameters are password protected. **ATTEMPTING TO CHANGE PARAMETERS WILL VOID WARRANTY AND CAN CAUSE SERIOUS INJURY OR DEATH!**

WARNING: In the event that the motor cable is replaced at the installation site, **THE INSTALLER MUST VERIFY CORRECT ROTATION OF THE MOTOR AND THAT THE WIRING PATTERN IS CORRECT! SERIOUS INJURY OR DEATH MAY OCCUR IF THE SYSTEM IS OPERATED IN REVERSE!**

Electrical Installation - Controller, VFD - continued

This section concerns the electric motor and control box for BADUJET Turbo swimjet system.

CAUTION: There is 100ft of cable included with the LED push buttons. If a longer distance to the control box is required, a junction box can be installed above the water line to splice additional cable as required.

BONDING: As required by National Electrical Code, the pump motor must be electrically bonded to the pool structure (reinforced bars, etc.) by a solid copper conductor not smaller than No. 8 AWG (6 AWG for Canada) via the external copper bonding lug on the pump motor. In addition, all metal parts larger than 4 in. in the pool must be bonded.

- Glue the bonding adapter to the port on the back of the jet housing with the grey plug. See Figure 13. There is a hole pre-drilled in the plug in order to feed the bonding wire through the housing.
- Insert the bare-end of the included 8AWG bonding wire through the front of the jet housing and bonding adapter. See Figure 14.
- When installing the clamping ring (*part# 18*), insert the copper strap at the end of the wire through the center hole on the left side of the cover (looking at front of housing) as shown in Figure 15.
- After suction cover is installed and the copper strap is located correctly, tighten the strain relief on the bonding adapter to create a seal around the wire.
- The copper strap will make contact with the back of the stainless steel cover once it is installed during the final assembly. It is secured between the stainless steel and plastic covers with one of the stainless steel cover screws (*part# 56.1*).



Figure 13



Figure 14



Figure 15

GROUNDING: Permanently ground the pump motor and control box using a conductor of appropriate size.

- **Pump Motor:** Connect to the #10 green headed ground screw provided inside the motor terminal box.
- **Control Box:** Connect to the aluminum grounding terminal strip on the inside of the control box enclosure.

CAUTION: DO NOT connect to electric power supply until the unit is permanently grounded.

1. Mount the control box and VFD together at the equipment pad. See Figure 1.

2. Wire according to the diagram included with the control box. Incoming power from the breaker panel (208-240VAC, 1PH, 60Hz), goes to the input side of the control box. The control box then supplies power to the VFD.

Electrical Installation - Controller, VFD - continued

3. The VFD is pre-programmed with all necessary parameters.

WARNING: Parameter set and programming of the VFD are completed at the factory. This ensures that the motor is "tuned" to the VFD, and that motor rotation is correct. Parameters are locked and extended parameters are password protected. **ATTEMPTING TO CHANGE PARAMETERS WILL VOID WARRANTY AND CAN CAUSE SERIOUS INJURY OR DEATH!**

4. Connect the included motor cable to the plug on top of the motor. Connect the three black wires to the U,V,W terminals of the VFD. The PTC thermistor wires (brown, white) are installed at VFD terminals 4 and 5. Green/yellow wire connects to GND.

5. **VERIFY CORRECT ROTATION.** When first starting the system, correct rotation **MUST BE VERIFIED**. Correct rotation is counter-clockwise (CCW) when looking at the propeller from the front of the swimjet. **SERIOUS INJURY OR DEATH MAY OCCUR IF THE SYSTEM IS OPERATED IN REVERSE.**

WARNING: DO NOT RUN THE SYSTEM DRY OR PERMANENT DAMAGE TO THE PROPELLER MAY OCCUR.

Connecting the SPECK controller to a WiFi network for the FIRST TIME:

1. Before connecting the SPECK controller to the WiFi network, stand where the SPECK equipment is located and with your mobile device in-hand assure that the signal strength to the WiFi network is good to excellent (*weak signals will cause problems*).

2. Make sure the power to the SPECK Device is turned ON. There is a green indicator on the controller board to indicate power. A small "o" will be flashing on the LED display.

3. Give the homeowner the BADUConnect app manual and allow them to finish the App setup. *For more information, Call (800) 223-8538 or visit www.baduconnect.com for additional copies of the BADUConnect App instructions.*

Figure 16

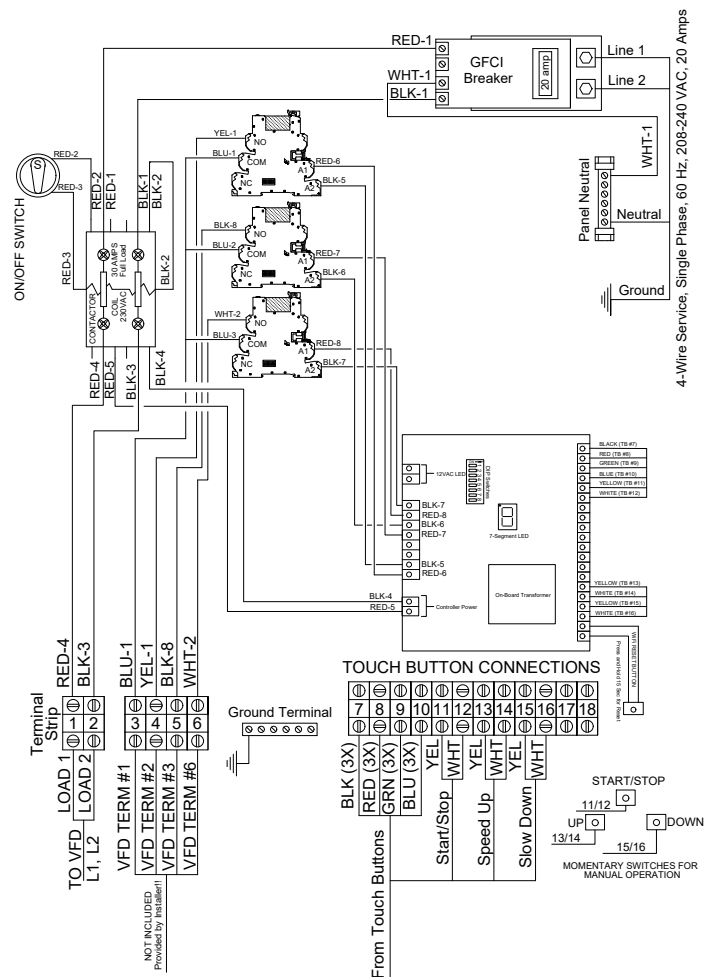

3 Service and Maintenance

Stainless Steel

Stainless Steel can provide an outstanding combination of aesthetic appeal, corrosion resistance, strength, durability, and clean ability, and they are commonly used for a wide range of indoor and outdoor pool applications, including ladders, handrails, diving platforms, and slide assemblies. These components are frequently still structurally sound and aesthetically pleasing after more than 25 years of service.

The BADUJET Turbo cover is made from high grade 316L polished stainless steel, often referred to as marine grade. It is ideal for immersed in pool applications or higher temperature pool and spa applications. The following are suggestions for maintaining the stainless:

1. After installation and before filling of the pool, thoroughly clean all stainless parts.
2. Maintain pool water chemistry. Poor water chemistry control can damage any metal or lessen the life of the pool or equipment.
3. Muriatic acid should not be used to clean concrete or tile near stainless steel. If Muriatic Acid comes in contact with stainless steel, it should be washed off and neutralized immediately.
4. Carbon steel wool or wire brushes should never be used for cleaning stainless.
5. Super chlorination (Shocking) should only be performed when necessary. High levels of chlorination can be minimized or eliminated through careful water management.
6. When shocking the pool, the pump should be maintained on its highest speed until chlorine levels return to normal.
7. If the pool level is dropped, and the swimjet is exposed to air, hose down surfaces with fresh clean water or wipe down with fresh clean water using a sponge or lint free cloth. **DO NOT** use acid, oil based cleaners, or wax. Light staining may be removed with a water-dampened cloth or with vinegar or ammonia cleaning solutions (e.g. window and surface cleaners).
8. Pool chemicals should never be added in or around the swimjet.

With proper maintenance, the BADUJET Turbo is designed for a lifetime *of enjoyment*.

Winterizing

In areas subject to freezing water temperatures, you should protect your equipment. We recommend you purchase winter cover kit part# 2328120050K. The kit includes one (1) winter plate with self-adhering gasket and eight (8) screws to mount to the front of the swimjet.

Also, you can protect your swimjet system by simply draining the swimming pool to a level below the jet housing.

Figure 17

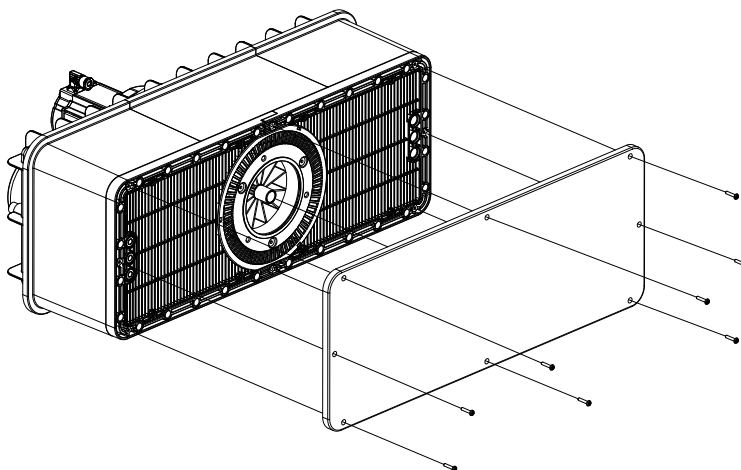

4 Product Specification

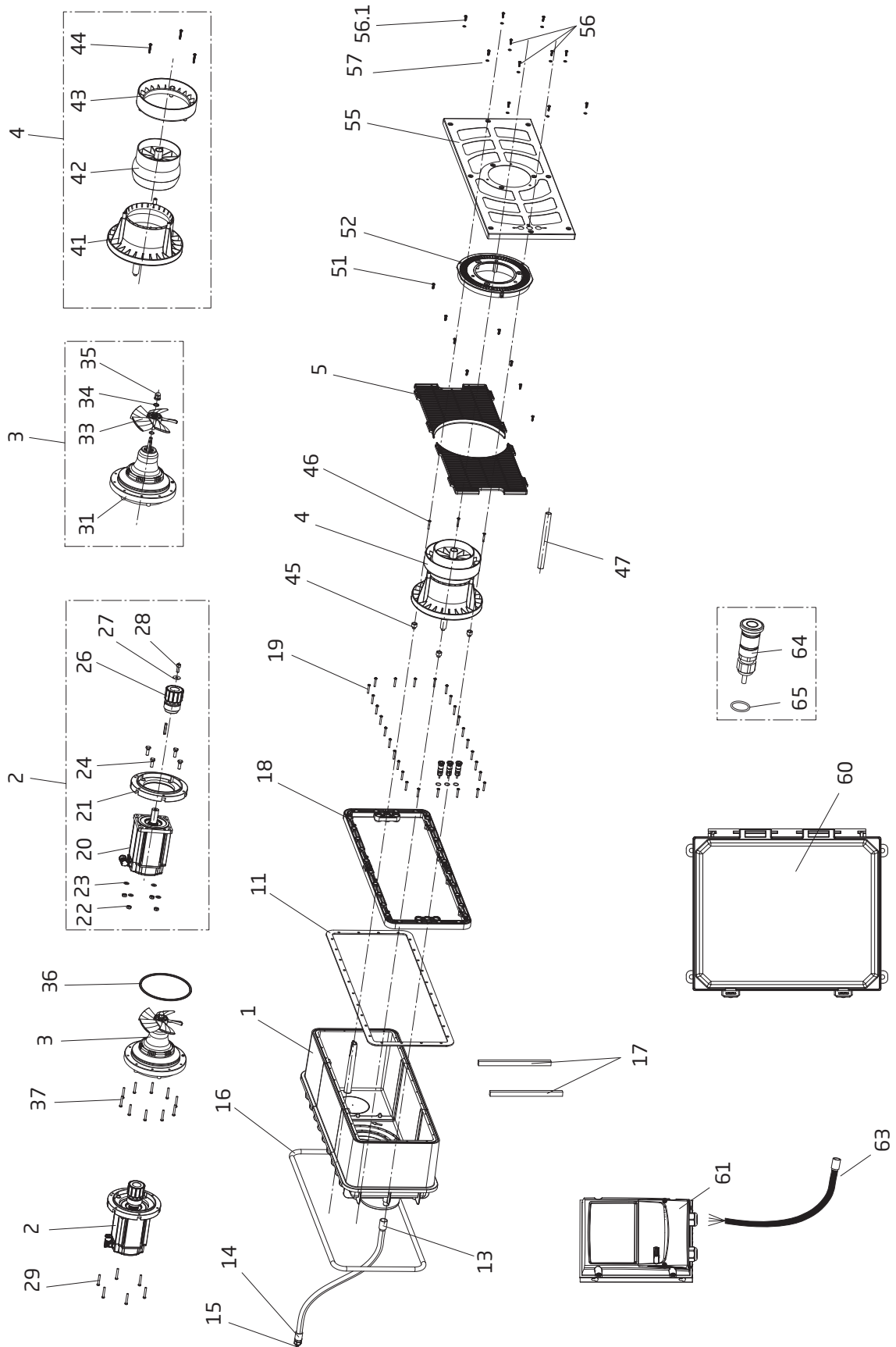

Replacement Parts

Order#	Drawing #	Qty Required	Description
2328000100A	1	1	Housing CPL w/ Housing Tapping Screws, Washers, Support slats, Foam tape, & Epoxy
2328150001	2	1	Motor Unit
2325023100	3	1	Propeller Unit
2325023200	3, 36 & 37	1	Propeller Unit CPL
2325010200	4	1	Nozzle Unit CPL
2328009301	5	2	Suction Grate
2328002700	11	1	Gasket, Housing
5862432531	13	1	Connector Conduit M25 x 3/4"
2326000033	14	1	3/4" Fem. Adapter, Strain Relief
2326000031	15	1	Strain Relief (3 x 7mm, 3/4" NPT)
2326000020	16	1	Round Sealing Cord 3.8mm (for concrete pools)
2325000405	17	2	Wood Support, 20 x 220 x 325mm (for concrete pools)
2328002801	18	2	Clamping Ring
5879006041	19	28	Tapping Screws - 6 x 40mm, A4
5266342	20	1	Motor - 2HP
2325059800	21	1	Intermediate Flange
5879341000	22	4	Nut - Motor M10, A4
5871251000	23	4	Washer - Motor 10.5mm, A2
5879331036	24	4	Hex Bolt - Motor, M10 x 35mm, A4
2325084705	26	1	Inner Rotor CPL (w/ Magnets)
5879021100	27	1	Washer - Motor, 10.5 x 30mm, A2
5879121025	28	1	Bolt - Motor, M10 x 25mm, A2
2991000091	29	6	Screw - Motor - Hex/Slot M7 x 48mm, SS
2325016101	31	1	Seal Housing CPL w/ Magnet
2325023000	33	1	Propeller
2923541222	34	1	O-ring - Propeller 16.9 x 2.75mm Viton
2923592202	35	1	Impeller Nut, M12
2325006200	36	1	O-ring - 212 x 7mm, NBR
2991000091	37	10	Screw - Motor - Hex/Slot M7 x 48mm, SS

Order#	Drawing #	Qty Required	Description
2325010210	41	1	Inlet Nozzle
2325005400	42	1	Ball Nozzle CPL, 180mm
2325005900	43	1	Nozzle Flange
5879006041	44	3	Tapping Screw - Nozzle - 6 x 40mm, A4
2325010240	45	1	Adaptors Set - Nozzle
5879006041	46	3	Tapping Screw - 6 x 40mm, A4
2325005500	47	1	Adjustment Tool
2325009321	52	1	Center Cover
2328009315A	55	1	Plastic Cover
5879006024	56	3	Tapping Screw - Front Cover - 6 x 22mm, A5
2991000146	56.1	16	Screw - M6 x 20mm, For Suction Grate and Front Cover
5871250602	57	11	Washer - M6, Clear (For Stainless Steel Cover ONLY)
2920280743	60	1	Control Box - BJC TURBO
ODE31200701F1A	61	1	VFD
2325000013A	63	1	VFD Motor Cable, 10m (shipped prior to 12/2023)
2336002899T	64 & 65	3	LED Push Button CPL w/ Cable, O-rings & ferrules

Optional Parts

2328009311A	55	1	Stainless Steel Cover (Bubble Design)
2328009310A	55	1	Stainless Steel Cover (Standard Design)
7300050000	Not Shown	1	Bonding Adaptor (for Stainless Steel Cover)
7300050001	Not Shown	1	Bonding Wire Assembly (for Stainless Steel Cover)
2325000014A	63	1	VFD Motor Cable, 80 ft. (shipped after 12/2023)
2325000015A	63	1	VFD Motor Cable, 150 ft.
2336002869A	64	3	100 ft. LED Push Button CPL w/ Cable, O-rings & ferrules
2601001902	Not Shown	4	Aqua Bond Epoxy (for concrete install)
2601001906	Not Shown	1	Foam Tape (for concrete install)
2328120050K	Not Shown	1	Winter Cover Kit

5 Limited Warranty

Product Registration

Thank you for purchasing a SPECK PUMPS® product please take a few moments to register it online. Your registration helps us keep you up to date on product information and offers.

Before you register:

What do I need to get started?

- The Serial Number and the Model Name
- An email address. We will use this to send you confirmation of your registration.
- A copy of your sales receipt and/or qualified installer's invoice.

To register your SPECK equipment please register online at www.usa.speck-pumps.com/register/

or

Scan QR code to register product



Limited Warranty

Speck Pumps-Pool Products, Inc. grants solely to the original consumer purchaser ("Buyer") of the BADUJET Turbo SwimJet System(s) the following personal, non-transferable and limited warranty on the following terms and conditions (the "Limited Warranty"): the BADUJET Turbo SwimJet System(s) is warranted to be free of material defects in materials or workmanship under normal use for a period of two (2) years beginning on the date of the Buyer's purchase of the BADUJET Turbo SwimJet System(s) (the "Limited Warranty Period"). Notwithstanding any provisions herein to the contrary, the warranties and obligations hereunder shall not in any event extend for more than three (3) years beyond the date of shipment of the BADUJET Turbo SwimJet System(s) from the factory (the "Limited Warranty Period"). The Limited Warranty is subject to each of the following additional terms and conditions:

1. IN THE EVENT OF ANY BREACH OF THE LIMITED WARRANTY, SPECK PUMPS-POOL PRODUCTS, INC.'S ENTIRE OBLIGATION AND LIABILITY TO BUYER, AND BUYER'S SOLE AND EXCLUSIVE REMEDY SHALL BE AS FOLLOWS: Speck Pumps-Pool Products, Inc. will, at its option, either repair or replace the BADU SwimJet System(s) or refund to Buyer the purchase price actually paid by Buyer for the BADUJET Turbo SwimJet System(s) subject to the Limited Warranty. Speck Pumps-Pool Products, Inc. shall have no obligations under the Limited Warranty unless Buyer delivers timely written notice to Speck Pumps-Pool Products, Inc. of the Limited Warranty claim within the Limited Warranty Period and returns the BADUJET Turbo SwimJet System(s) to Speck Pumps-Pool Products, Inc. if requested. To the fullest extent permitted by law, Speck Pumps-Pool Products, Inc. expressly disclaims any liability for, and the Limited Warranty does not include or cover, any labor, costs or other expenses in connection with the removal, transportation, shipment, insurance, replacement, repair, or installation of repaired or replaced parts or for any other costs or expenses or damages to property or things including, but not limited to, those arising in connection with the use of, or inability to use, the BADUJET Turbo SwimJet System(s).

2. To the fullest extent permitted by law, the Limited Warranty will be void and of no force or effect and Speck Pumps-Pool Products, Inc. will have no liability, responsibilities or obligations to Buyer or with respect to the BADUJET Turbo SwimJet System(s) in the event of the occurrence of any one or more of the following:

- (a) Any damage to the BADU SwimJet System(s) caused by Buyer, any third party, ground movement, other natural forces, acts of God or any other sources or causes not arising from a breach of the Limited Warranty, excluding ordinary wear and tear;
- (b) Any replacement, modification, alteration or repair of any parts or components of the BADU SwimJet System(s) by anyone other than Speck Pumps-Pool Products, Inc.;
- (c) Any abuse, misuse, accident, tampering with, improper installation or modification of the BADU SwimJet System(s) or any other actions, inactions or failures to act that violate the terms and conditions of this Limited Warranty;
- (d) Buyer's failure or inability to present an invoice, bill, receipt or other documentation clearly evidencing that the BADU SwimJet System(s) was installed and maintained in strict compliance with this Limited Warranty and that the claim was timely submitted within the Limited Warranty Period; and/or
- (e) Buyer's failure to comply with the conditions and contingencies set forth in paragraph 3 below.

3. The Limited Warranty is expressly conditioned and contingent upon Buyer's strict compliance with each of the following:

- (a) Installation of the BADU SwimJet System(s) by an experienced and qualified pool industry professional and a licensed electrician who is licensed within the jurisdiction in which the BADU SwimJet System(s) is installed and will be used; and

Limited Warranty - continued

- (b) Buyer's operation and maintenance of the BADU SwimJet System(s) in strict accordance with Speck Pumps-Pool Products, Inc.'s printed operator/maintenance manuals delivered with the BADU SwimJet System(s).

4. DISCLAIMER: THE LIMITED WARRANTY IS THE ONLY WARRANTY MADE AND IS IN LIEU OF ALL OTHER WARRANTIES, AND ANY AND ALL IMPLIED WARRANTY OR CONDITION OF MERCHANTABILITY, THE IMPLIED WARRANTY AGAINST INFRINGEMENT, AND THE IMPLIED WARRANTY OR CONDITION OF FITNESS FOR A PARTICULAR PURPOSE ARE EXPRESSLY LIMITED IN THEIR SCOPE AND DURATION TO THE ONE YEAR TERM OF THE LIMITED WARRANTY SET FORTH HEREIN. SOME STATES DO NOT ALLOW LIMITATIONS ON HOW LONG AN IMPLIED WARRANTY LASTS, SO THE ABOVE LIMITATION MAY NOT APPLY TO THE BUYER.

5. TO THE FULLEST EXTENT PERMITTED BY LAW, IN NO EVENT SHALL SPECK PUMPS-POOL PRODUCTS, INC. OR ITS OFFICERS, DIRECTORS, EMPLOYEES, SHAREHOLDERS, AGENTS, OR REPRESENTATIVES BE LIABLE FOR ANY SPECIAL, INDIRECT, INCIDENTAL, EXEMPLARY OR CONSEQUENTIAL DAMAGES OR LOSS, INCLUDING TIME, MONEY, GOODWILL, AND LOST PROFITS IN ANY WAY WHICH MAY ARISE HEREUNDER OR FROM THE USE OF OR INABILITY TO USE THE BADU SWIMJET SYSTEM(S) OR THE PERFORMANCE OR NONPERFORMANCE OF ANY OBLIGATION UNDER THIS LIMITED WARRANTY. THIS PARAGRAPH, THE WARRANTY DISCLAIMERS IN PARAGRAPH 4 ABOVE, AND THE SOLE AND EXCLUSIVE REMEDY SET FORTH IN PARAGRAPH 1 ABOVE SHALL APPLY EVEN IF SPECK PUMPS-POOL PRODUCTS, INC. HAS BEEN NOTIFIED OF THE POSSIBILITY OR LIKELIHOOD OF SUCH DAMAGES OCCURRING, WHETHER SUCH LIABILITY IS BASED ON CONTRACT, TORT, NEGLIGENCE, STRICT LIABILITY, PRODUCTS LIABILITY OR OTHERWISE, AND EVEN IF ANY REMEDY STATED HEREIN FAILS OF ITS ESSENTIAL PURPOSE. SOME STATES DO NOT ALLOW THE EXCLUSION OR LIMITATION OF SPECIAL, INDIRECT, INCIDENTAL, EXEMPLARY OR CONSEQUENTIAL DAMAGES OR LOSS, SO THE ABOVE EXCLUSIONS AND LIMITATIONS MAY NOT APPLY.

6. This Limited Warranty gives the Buyer specific legal rights, and the Buyer may also have other rights, which vary from state to state.

7. A return merchandise authorization ("RMA") must be obtained from Speck Pumps-Pool Products, Inc. before returning any product. Products returned without an RMA will be refused and returned, unopened, to the Buyer. All returned products are to be sent freight prepaid and insured for Buyer's protection to the manufacturer at 8125 Bayberry Road, Jacksonville, Florida 32256 USA. Under no condition will products be accepted after the expiration of the Limited Warranty Period. Speck Pumps-Pool Products, Inc. shall not bear any costs or risks incurred by Buyer in shipping a defective BADU SwimJet System(s) to Speck Pumps-Pool Products, Inc. or in shipping a repaired or replaced BADU SwimJet System(s) to Buyer.

