

C2 rondo

GB Operating Instructions

Translation of the original

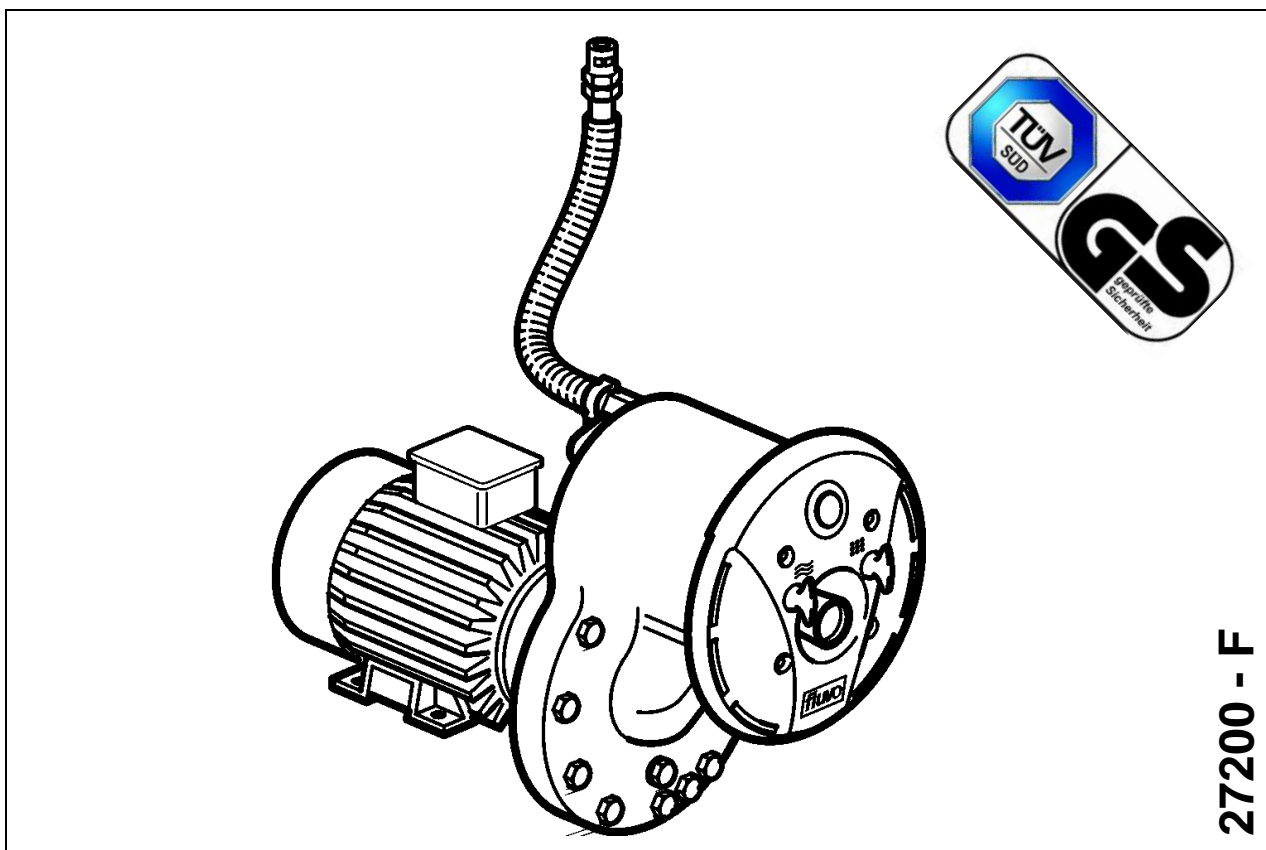

Contents

1	General	4
1.1	Guarantee notice	4
1.2	General	4
1.3	Usage Instructions	4
2	Safety Instructions	2
2.1	General	4
2.2	Symbols	5
3	Unit Description / General Technical Data	5
3.1	Technical Data	5
3.2	Device Units	5
4	Installation Site Specifications / Installation	8
4.1	Planning the pump pit	8
4.2	Installation preparations / Concrete pool	9
4.3	Installation preparations / Pre-fabricated pool	9
4.4	Installation preparations / Wooden-liner pool.....	10
4.5	Pump kit Installation / Concrete-tile pool.....	10
4.6	Pump kit Installation Concrete-liner pool	11
4.7	Installation kit and Pump kit Installation / Pre-fabricated pool.....	11
4.8	Mounting the installation kit / Wooden-liner pool	12
4.9	Installing the switchgear cabinet	13
4.10	Non-return air valve installation	13
4.11	Installation of the face plate assembly - general.....	14
5	Electrical Connections	16
5.1	Electrical Connections - general	16
5.2	Electrical Connections AC	17
5.3	Electrical Connections three-phase current	18
6	Start-up / Operating	19
7	Fault Assistance	20
8	Shutdown / Overwintering	21
8.1	Empty the pool	22
8.2	Face plate assembly overwintering.....	22
8.3	Draining the pump.....	22
9	Maintenance and Repair	22
9.1	General	22
9.2	Maintenance	22
9.3	Repairs.....	22
10	Spare Parts List and Drawing	23
10.1	Spare Parts List	23

1 General

1.1 Guarantee notice

If the instructions contained in this operator's manual are not observed then any claims under guarantee shall be void.

1.2 General

All parts coming into contact with media are designed for water quality to **DIN 19643**.

The counter-current swimming unit (counter-current unit) is of state-of-the-art technology. It has been manufactured with great care and is subject to constant quality checks. It has been approved by the German Technical Inspectorate (TÜV) and awarded the TÜV-GS (safety standard) mark.

The operator's manual contains important instructions on how to use the counter-current unit safely, properly and economically. The instructions must be strictly adhered to in order to avoid danger and to ensure that the counter-current unit has a long useful life.

This manual does not take into account local regulations, the observance of which is the responsibility of the operator – also on behalf of installation personnel that may be involved.

The performance label specifies the machine series, the frame size, the most important operating data and the serial number. Please be sure to quote it in case you require more information and also when placing subsequent orders or ordering spare parts.

1.3 Usage Instructions

The counter-current unit was designed for use in private swimming pools. Consequently it must not be installed in public swimming pools. Neither the entire unit nor parts thereof must be used in other systems. You are expressly directed to use it only in accordance with these instructions.

The counter-current unit must not be operated beyond the parameters stated in the technical data (3.1) . In case of doubt, please contact your customer service or the manufacturer.

2 Safety Instructions

2.1 General

- Make sure that the relevant safety regulations and laws are observed in the operating company and / or country where the counter-current systems are to be used.
- All parts that come into contact with the medium are resistant to an absolute salt content of up to 0.75% (4,500 mg/l Cl⁻). If the salt concentrations are greater than this, the manufacturer must be consulted.
- Use the counter-current system only if it is in perfect technical condition, in accordance with the regulations, observing safety requirements and danger conditions and strictly adhering to all the instructions in the operator's manual!
- Promptly remedy any faults that could influence safety.
- Prior to carrying out repairs to the counter-current system it must be isolated from the electrical supply and protected from unintentional switching on.
- Regardless of what nature they may be, repairs must only be carried out by qualified persons and the counter-current system must be emptied first.

- The operator must ensure that
 - the operator's manual is always available for users to read,
 - instructions in the operator's manual are being observed,
 - the counter-current system is immediately stopped if abnormal electrical voltages, temperatures, noises, vibrations, leakages or other faults should arise.

	For more details of safety instructions please see the brochure Safety Instructions (27228-A).
---	--

2.2 Symbols

In these operating instructions the following symbols are used to draw your special attention to dangers:

	Warning! Risk of injury! / Warning! Risk of damage! This symbol warns you of dangers through mechanical effects and also warns of handling that could damage the product.
---	---

	Warning! Mortal danger! This sign warns you of the danger from electric shocks.
---	---

Notices attached directly to the counter-current system , e.g. the arrow indicating the direction of rotation, must always be observed and maintained in a clearly legible condition.

3 Unit Description / General Technical Data

- The counter-current system complies with VDE (Association of German Engineers) regulations.
- The electric motor and the water conducting plastic pump are electrically separated.
- The electric motor complies with protection class IP 55.
- The entire counter-current system complies with protection class I.

The counter-current system is delivered as 3 assemblies:

1. Pump kit
2. Assembly kit
3. Installation kit

3.1 Technical Data

System type:	C2 rondo 1,9	C2 rondo 1,9 WS *	C2 rondo 3,0
Capacity	1.9 kW	1.9 kW	3.0 kW
Voltage [V]	400 Y / 230 Δ	230 V ~	400 Y / 230 Δ
Frequency	50 Hz	50 Hz	50 Hz
Current	4.4 A / 7.8 A	11.8 A	6.5 A / 11.5 A
Speed	2850 rpm	2820 rpm	2810 rpm
Delivery capacity	48 cbm/h	48 cbm/h	60 cbm/h
Delivery pressure	1.4 bar	1.4 bar	1.9 bar
Max. speed 2 m from the nozzle	1.3 m/s	1.3 m/s	1.6 m/s
Max. water temperature	50 °C	50 °C	50 °C
Expected sound pressure level	67 + 2 dB (A)	65 + 2 dB (A)	70 + 2 dB (A)
Weight	22 kg	23 kg	27 kg

*AC = Alternating current

3.2 Device Units

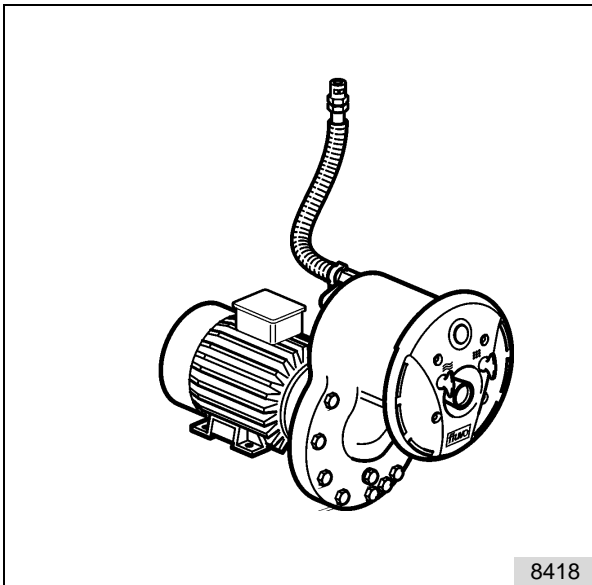

fig. 1

Overview of the Counter-current unit

The counter-current unit consists of:

1. Pump kit
2. Assembly kit
3. Installation kit

The installation kit is always different depending on the pool type.

There are 4 kinds of pool:

- Concrete-tile pool
- Concrete-liner pool
- Pre-fabricated pool (steel, plastic or similar)
- Wooden-liner pool

* The item numbers correspond to the numbers in the parts list.

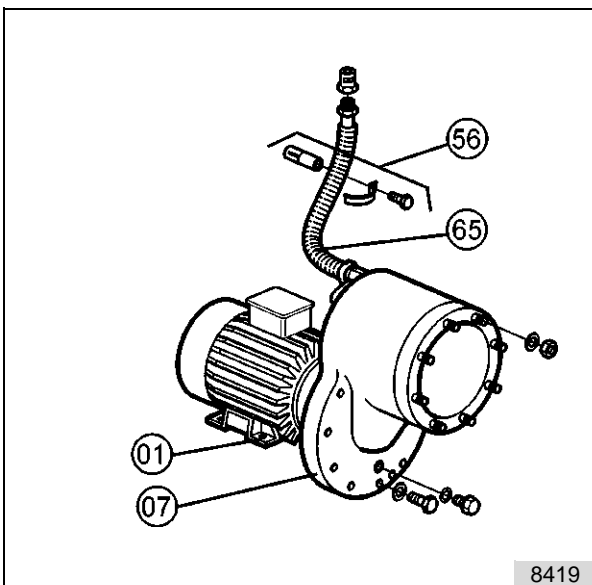

fig. 2

I - Pump kit

The pump kit consists of:

- | | |
|--------------------------------------|----------|
| 1. Pump assembly | Item 01* |
| 2. Suction housing | Item 84 |
| 3. Switching tube \varnothing 4 mm | Item 31 |
| 4. Switchgear cabinet | Item 02 |
| 5. Air line fixing bracket | Item 56 |
| 6. Air hose | Item 65 |

*The pump kit is always identical no matter what sort of pool it is intended for.

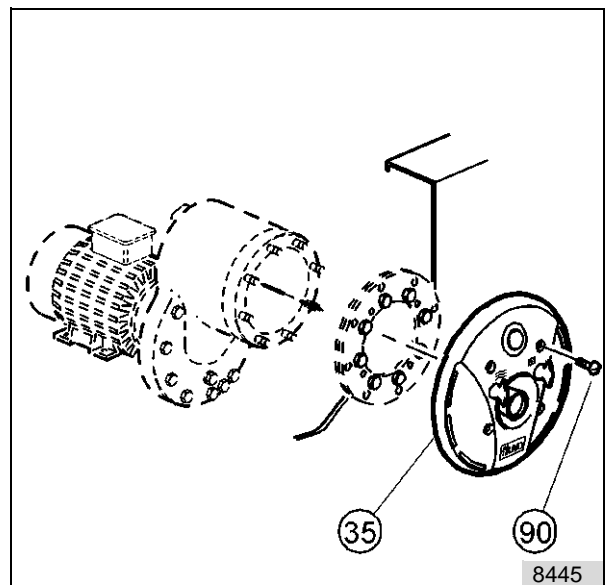

fig. 3

II - Assembly kit

The assembly kit includes:

- | | |
|------------------------|---------|
| 1. Face plate assembly | Item 35 |
| 2. Mounting screws | Item 90 |

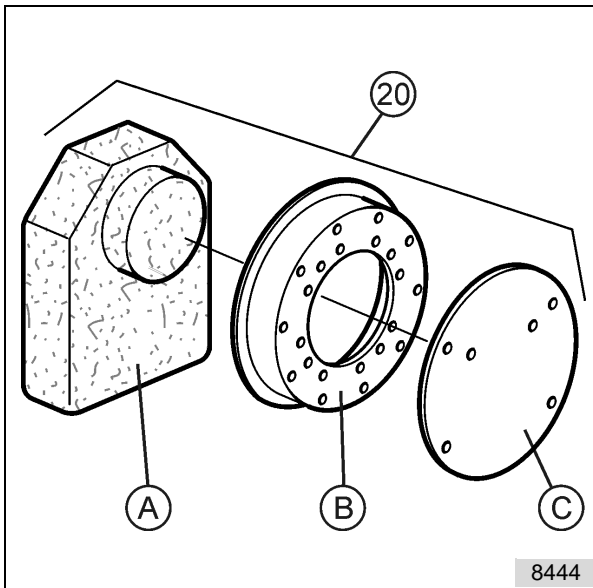

fig. 4

III - Installation kit for concrete-tile pool and Concrete-liner pool

The installation kit (Item 20) consists of:

- A Polystyrene filler piece
- B Housing
- C Protection film

The housing is concreted into the concrete wall of the pool. Details of this can be found in section 4 of this manual.

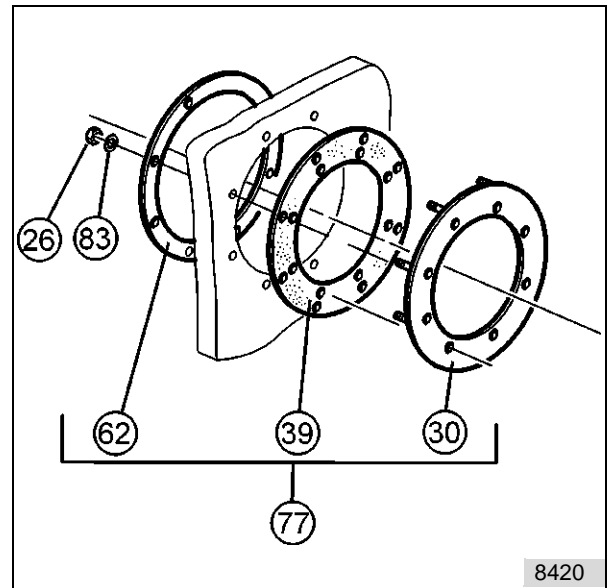

fig. 5

III - Installation kit for pre-fabricated pools

The installation kit (Item 77) consists of:

- | | |
|---------------------|-------------|
| 1. Clamp ring | Item 30 |
| 2. Clamp gasket | Item 39 |
| 3. Hold-ring | Item 62 |
| 4. Nuts and washers | Items 26/83 |

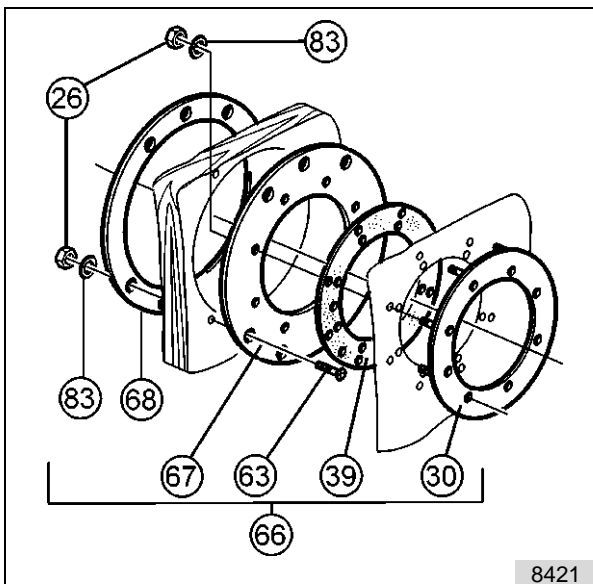

fig. 6

III - Installation kit for wooden-liner pool

The installation kit (Item 66) consists of:

- | | |
|---------------------|-------------|
| 1. Clamp ring | Item 30 |
| 2. Clamp gasket | Item 39 |
| 3. Hold-ring | Item 67 |
| 4. Hold-ring | Item 68 |
| 5. Mounting screws | Item 63 |
| 6. Nuts and washers | Items 26/83 |

4 Installation Site Specifications / Installation



Warning! Mortal danger!

If the motor is to be installed with a metal supporting foot, then it must be fastened insulated against the floor to avoid the transfer of spurious voltages to the device and swimming pool water.



Warning! Risk of damage!

As the pumps are not self-priming, the installation must be under water level. Make sure you take this into account during the installation planning phase.

4.1 Planning the pump pit

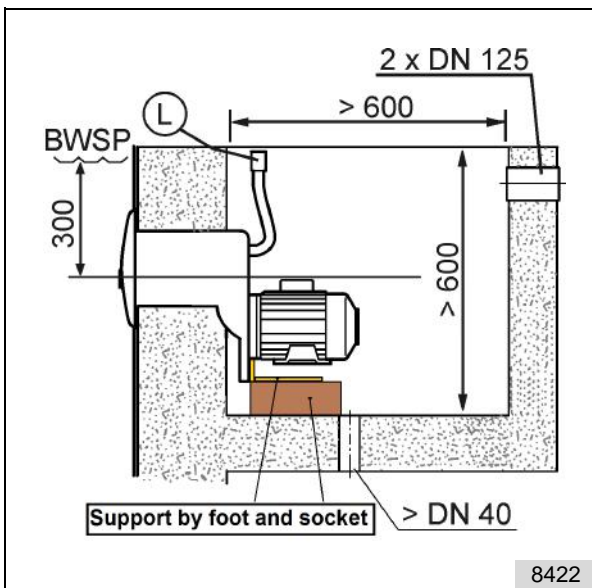

fig. 7: Cross-sectional view of the pump pit

BWSP Pool water level

L Air valve

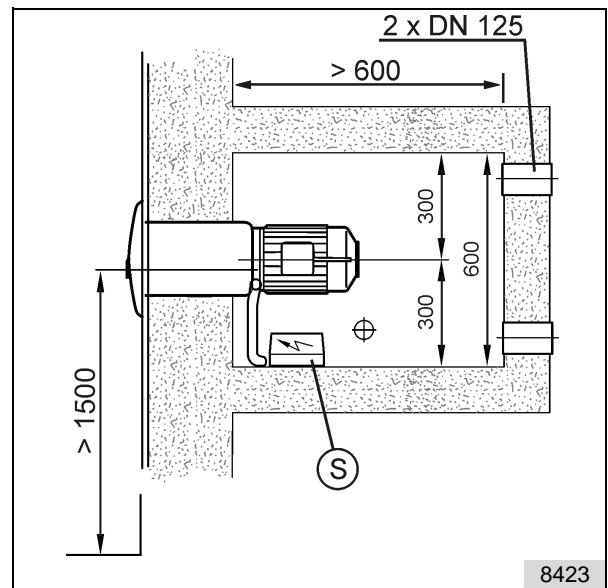

fig. 8: Top view of the pump pit

S Switchgear cabinet

When planning a pump duct take into account:

1. Clear dimensions min. 600 x 600 x 600
2. Return connection min. 300 mm under the pool water level
3. Leakage water discharge pipe-end min. DN 40
4. Cooling air supply for the motor min. 2x DN 125. Minimum clearance of the motor cooling air inlet to the wall = 200 mm.
5. Be sure to cover the pump pit if it is installed in the open air.



Warning! Mortal danger!

The mains power supply cable must be equipped with an all-pole separator with a contact opening of 3 mm.

6. The position of the non-return air valve (L) must always be over the pool water level (BWSP).
7. The position of the switchgear cabinet (S) must always be over the pool water level (BWSP).
8. In case of leakage from the pump, a suitable water drainage must be provided!

4.2 Installation preparations / Concrete pool

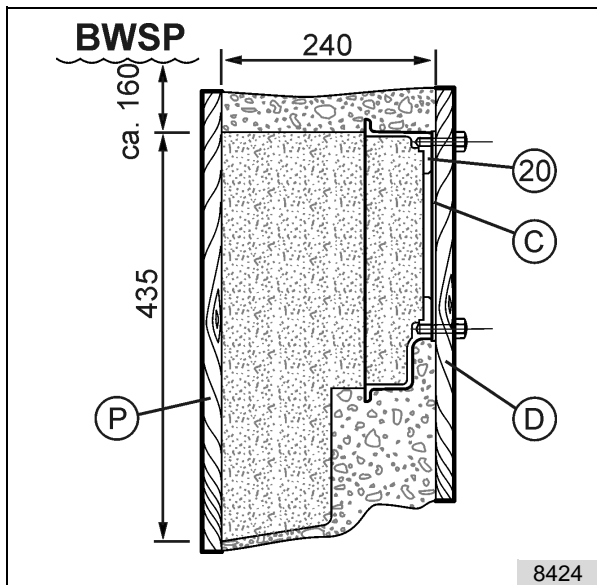

fig. 9

- A Polystyrene filler piece
- C Mounting protection film
- D Pool-side formwork board

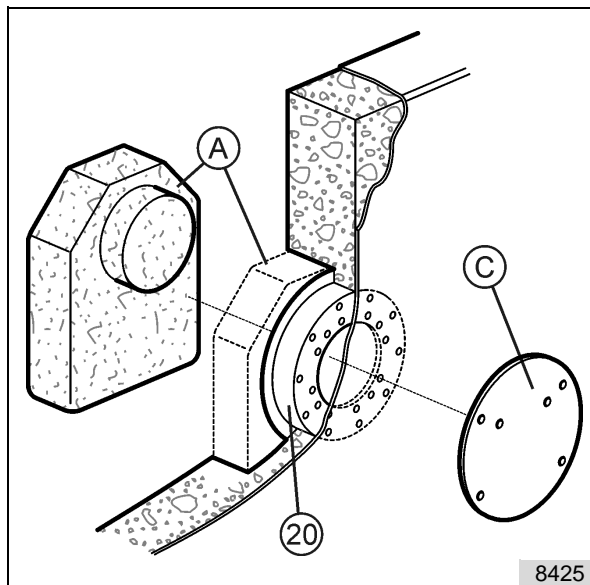

fig. 10

- P Formwork board
- 20 Installation kit

Tailor the installation kit:

Place the installation kit on the formwork board and transfer the bore holes. Bore the holes into the pool-side formwork board (D).

Screw the installation kit complete with the mounting protection film (C) tightly to the pool-side formwork board (D).

After removing the shuttering take off the polystyrene filler piece (A). Also remove the protection film (C).

4.3 Installation preparations / Pre-fabricated pool

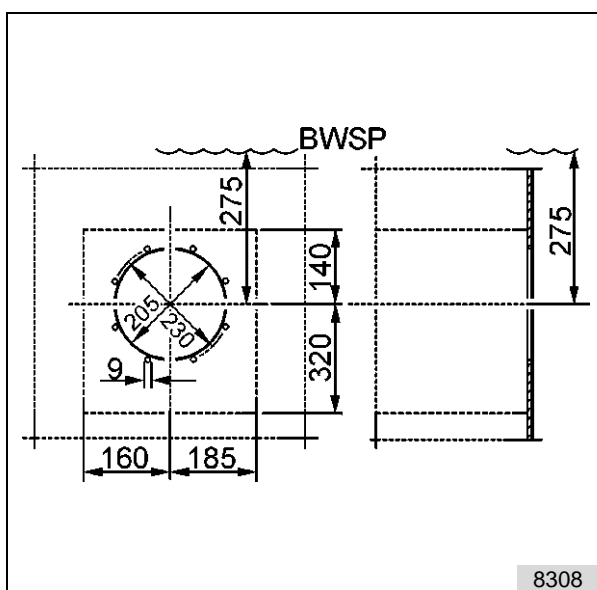

fig. 11: Boring diagram

Tailor the installation kit:

Cut the cavity \varnothing 205 and the mounting holes \varnothing 9 into the pool wall.



Warning! Risk of damage!

The hold-ring (62) must be used as a template.

For rear filling the pool ensure that there is a cavity at least the size of the dotted lines.

4.4 Installation preparations / Wooden-liner pool

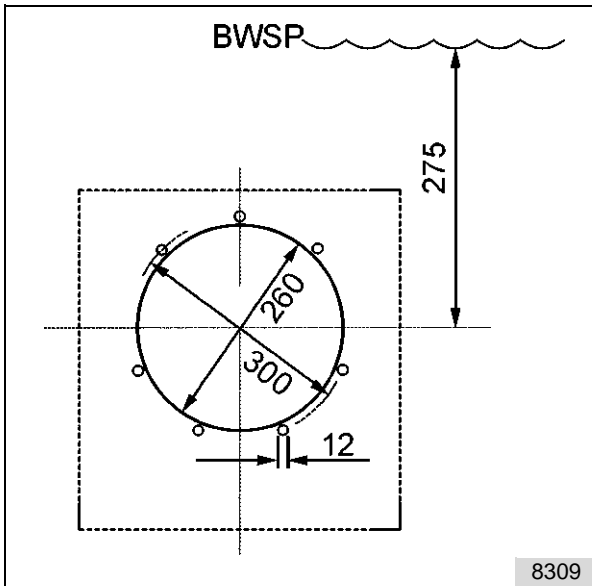

fig. 12: Boring diagram

Tailor the installation kit:

Cut the cavity \varnothing 260 and the mounting holes \varnothing 12 into the pool wall.



Warning! Risk of damage!

The hold-ring (68) must be used as a template.

Take note of the asymmetrical position of the holes!

4.5 Pump kit Installation / Concrete-tile pool

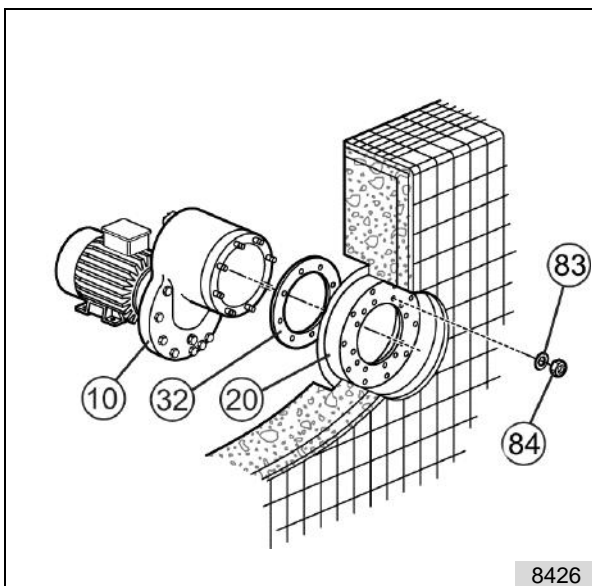

fig. 13

- 10 Suction housing
- 20 Installation kit
- 26 Nut
- 27 Distance washer
- 32 Clamp gasket

Mount the suction housing (10) with the clamp gasket (32) and the nuts (26) and washers (27) on the installation kit (20). The sealing contact faces must be clean and smooth.



Warning!

The suction housing (10) must be mounted so that the connection for the membrane switch is at the top.

4.6 Pump kit Installation / Concrete-liner pool

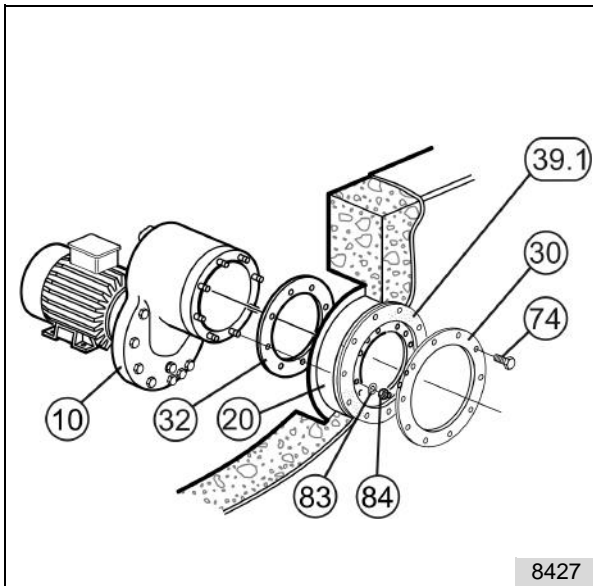

- 20 Installation kit
- 26 Nut
- 27 Distance washer
- 30 Clamp ring
- 32 Clamp gasket
- 39.1 Clamp gasket
- 74 Screw
- 84 Suction housing

fig. 14

Hang in the liner, mount with the clamp ring (30) and the screws (74) to the installation kit (20). The first gasket (39) should be between the installation kit (20) and liner, the second gasket (32) between the installation kit (20) and suction housing (84). Pierce the liner on the clamp ring (30) for the eight suction housing stay bolts.



Warning!

The suction housing (84) must be mounted so that the connection for the membrane switch is at the top.

4.7 Installation kit and Pump kit Installation / Pre-fabricated pool

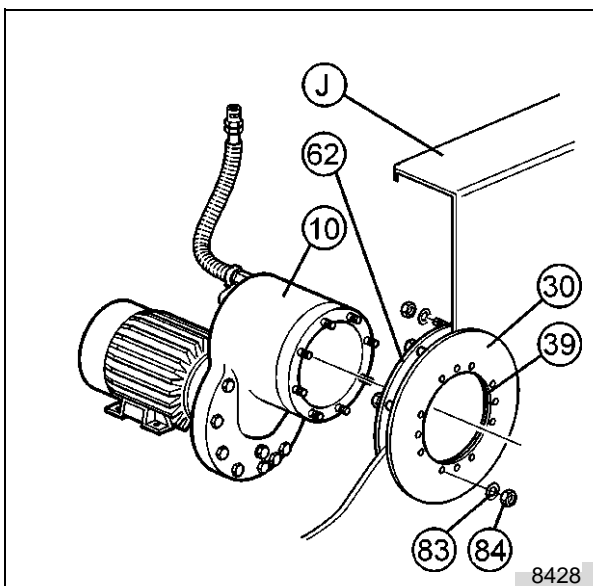

fig. 15

- J Pool wall
- 26 Nut
- 27 Distance washer
- 30 Clamp ring

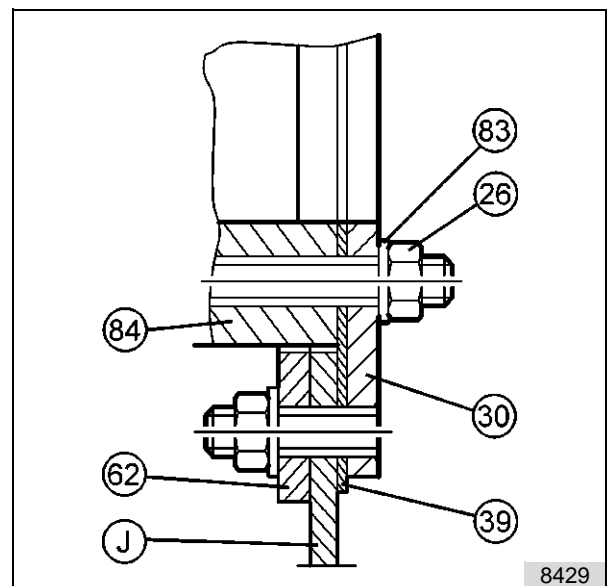

fig. 16: Detail from fig. 15

- 39 Clamp gasket
- 62 Hold-ring
- 83 Distance washer
- 84 Housing

Mount the clamp ring (30) with the clamp gasket (39) and the hold-ring (62) to the pool wall (J). The sealing contact faces must be clean and smooth.

Mount the housing (84) to the clamp ring (30) with the nuts (26) and distance washers (83).



Warning!

The housing (84) must be mounted so that the connection for the membrane switch is at the top.

4.8 Mounting the installation kit / Wooden-liner pool

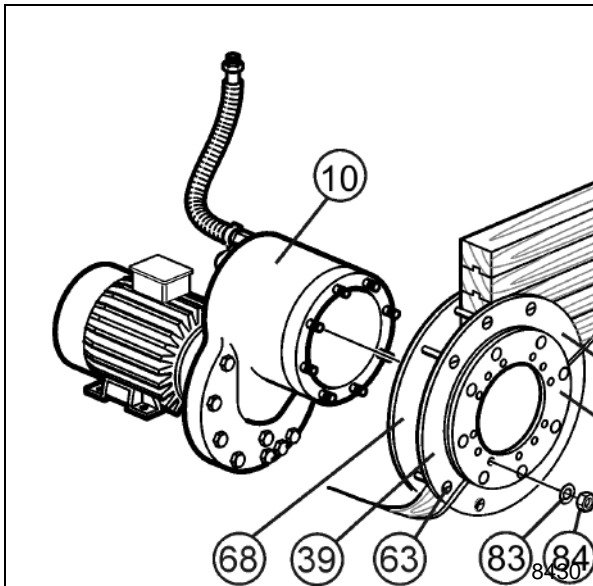

fig. 17

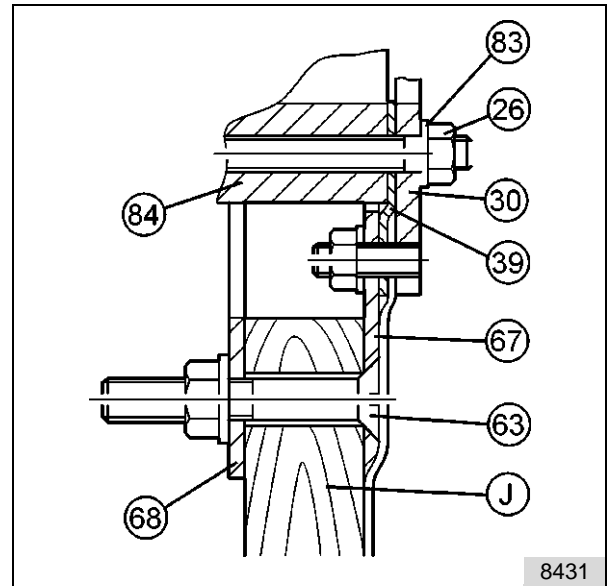

fig. 18: Detail from fig. 17

- J Pool wall
- 02 Switchgear cabinet
- 31 Switching tube
- 26 Nut
- 27 Distance washer
- 30 Clamp ring
- 39 Clamp gasket

- 63 Countersunk screw
- 67 Clamp ring
- 68 Hold-ring
- 83 Distance washer
- 84 Housing
- 85 Distance washer

Mount the hold-ring (67) with the clamp ring (68) to the pool wall.

Hang in the liner. Fasten the liner and the clamp gasket (39) together with the clamp ring (30) and cut out the liner.

Mount the housing (84) to the clamp ring (30) with the nuts (26) and distance washers (83).



Warning!

The housing (84) must be mounted so that the connection for the membrane switch is at the top.

4.9 Installing the switchgear cabinet

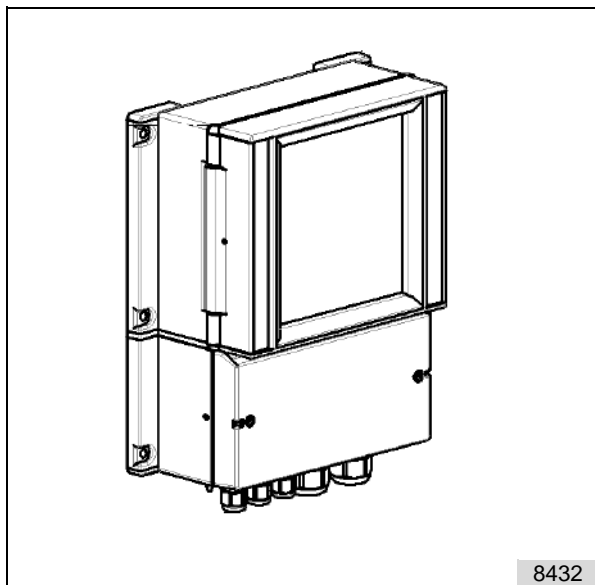

fig. 19

Connection information for Control NT switch, refer to the corresponding operating instructions 27248.

4.10 Non-return air valve installation

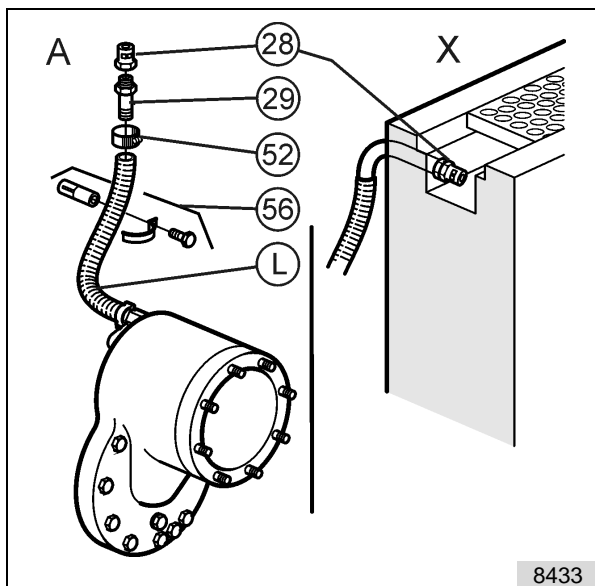

fig. 20

- L Air hose
- 28 Non-return air valve
- 29 Air line hose tail
- 52 Air pipe clamp
- 56 Fixing bracket

Fasten the non-return air valve with the fixing bracket (56) to the pool wall or similar. In the case of a ground level overflow, place the non-return air valve in the duct, see detail "X".



Warning!

To position the non-return air valve also please observe the information under chapter 4.1.

4.11 Installation of the face plate assembly - general

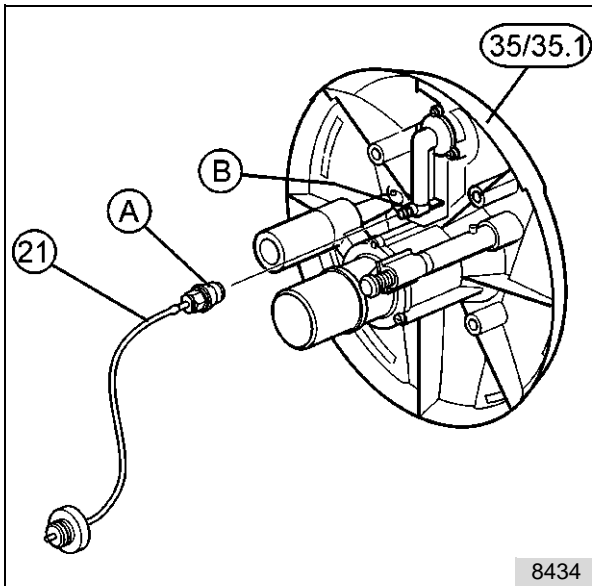

fig. 21

- A *Hose coupling*
- B *Plug sleeve*
- 21 *Hose*
- 35/35.1 *Face plate assembly for concrete pool*

Drain the pool water, if already filled, to below the installation kit. Firmly place the hose (21) with the hose coupling (A) onto the plug sleeve (B) on the face plate assembly (35/35.1). With that the air button is connected to the switchgear cabinet.

4.11.1 Face plate assembly installation / Concrete-tile pool

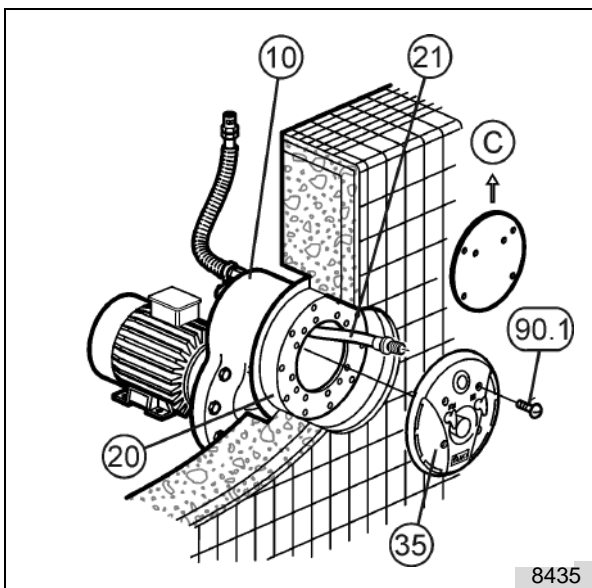

fig. 22

- C *Mounting protection film*
- 10 *Suction housing*
- 20 *Installation kit*
- 21 *Switching tube*
- 35 *Face plate assembly*
- 90.1 *Screw*

Remove the mounting protection film (C). After connecting the air button, put on the face plate assembly (35), this allows the pressure connection and air connection to slide into one another. Fasten to the installation kit (20) with the screws (90.1).



Warning!

Make sure that there is not a kink in the switching tube (21), lay it in a loop and do not shorten!

4.11.2 Face plate assembly installation / Concrete-liner pool

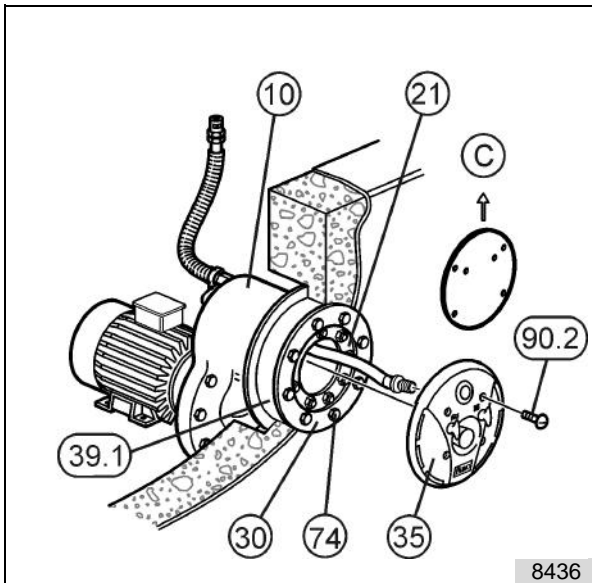

fig. 23

- C Mounting protection film
- 10 Suction housing
- 21 Switching tube
- 30 Clamp ring
- 35 Face plate assembly
- 39.1 Clamp gasket
- 74 Screw
- 90.2 Screw

Cut out the pool liner to fit. Remove the mounting protection film (C). Place the clamp gasket (39.1) between the installation housing and the liner and screw the clamp ring (30) to the installation housing using the screws (74). The sealing contact faces must be clean and smooth. After connecting the air button, put on the face plate assembly (35), this allows the pressure connection and air connection to slide into one another. Fasten to the clamp ring (30) with the screws (90.2).



Warning!

Make sure that there is not a kink in the switching tube (21), lay it in a loop and do not shorten!

4.11.3 Face plate assembly installation / Pre-fabricated pool

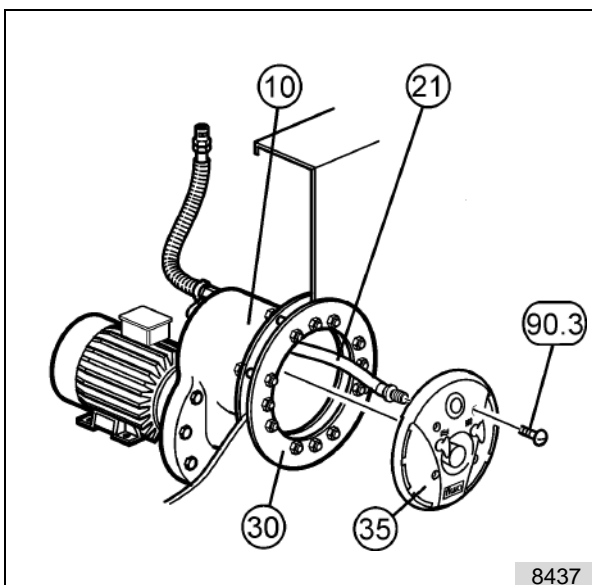

fig. 24

- 10 Suction housing
- 21 Switching tube
- 30 Clamp ring
- 35 Face plate assembly
- 90.3 Screw

After connecting the air button, put on the face plate assembly (35), this allows the pressure connection and air connection to slide into one another. Fasten to the clamp ring (30) with the screws (90.3).



Warning!

Make sure that there is not a kink in the switching tube (21), lay it in a loop and do not shorten!

4.11.4 Face plate assembly installation / Wooden-liner pool

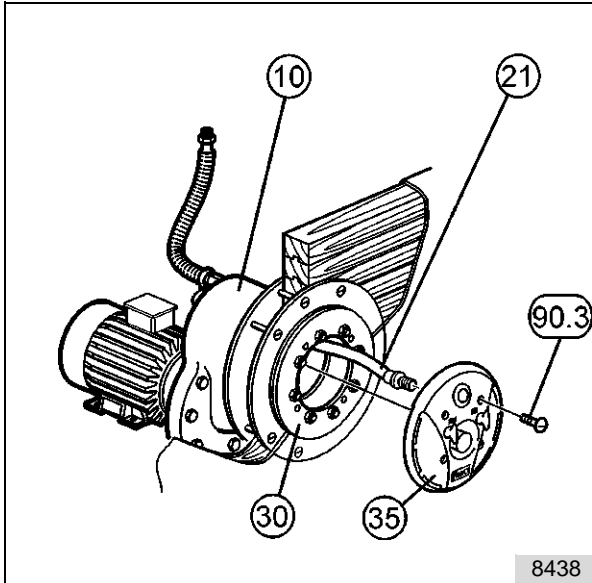

fig. 25

- 10 Suction housing
- 21 Switching tube
- 30 Clamp ring
- 35 Face plate assembly
- 90.3 Screw

After connecting the air button, put on the face plate assembly (35), this allows the pressure connection and air connection to slide into one another. Fasten to the clamp ring (30) with the screws (90.3).



Warning!

Make sure that there is not a kink in the switching tube (21), lay it in a loop and do not shorten!

5 Electrical connections

5.1 Electrical Connections - general

The electrical connections to the counter-current swimming system must be carried out by a specialised company in the electrical engineering branch approved by the local energy provider, taking into account the technical connection requirements.



Warning! Mortal danger!

The connections must be carried out by a qualified electrician. For this see for example the **Technical Connection Conditions for heavy Current from the power supply company**, the **Regulations of the Electrical Trade VBG (§3)** and **DIN VDE 1000-10 / 1995-5**. The relevant **DIN VDE directives 0100** and where there is a risk of explosion **0165** must also be observed. If the installation is not carried out properly, there is a risk of getting electric shocks!



Warning!

Compare the available power supply voltage with the details on the motor's factory plate and select the appropriate switching.

We recommend the use of a motor protection facility. Explosion protected motors, increased safety (Ex)-e and temperature class T3, must always be connected in accordance with DIN VDE 0170/0171 via a motor protection switch.

Connect the motor in accordance with the circuit diagrams in the following chapters.

Please observe:

- The mains power connection must be a fixed connection.
- Under no circumstances must there be any conducting connection between the metal parts of the motor and the water.
- An earth leakage circuit breaker (nominal fault current ≤ 30 mA) must be fitted to the mains power connection.
- At the marked connection terminal (at the foot of the motor or next to the terminal box) an equalising potential with a cross-section of 10 mm^2 must be fitted.

5.2 Electrical connections AC

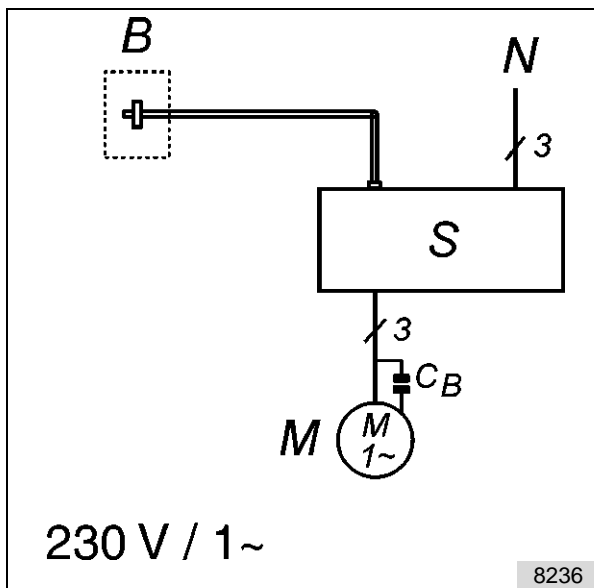

fig. 26

Mains voltage 230 V for 1 ~ AC
 Mains power supply cable: $3 \times 2.5 \text{ mm}^2$
 Pump power supply cable: $3 \times 2.5 \text{ mm}^2$
 Fuse: 16 A passive

B = Control unit in the pool
M = Motor of the circulation pump
N = Mains power supply (230 V for 1~)
S = Switchgear cabinet
C_B = Capacitor

Connection cable, for example, HO7RNF, all further details required for making connections can be found in chapter 3.1.

Protective measures:

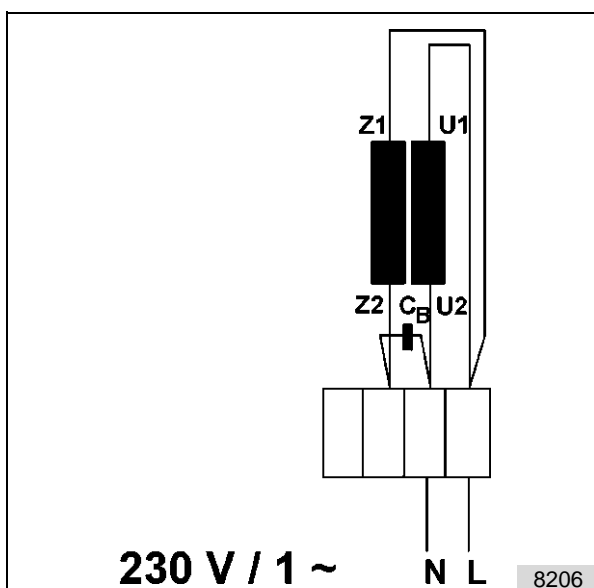

fig. 27: Basic circuit diagram for 230 V for 1 ~ AC



An earth leakage circuit breaker (nominal fault current ≤ 30 mA) must be fitted to the mains power supply!



Important: Watch the order of the terminal bridges!

See the inside of the terminal box lid or enclosed circuit diagram. Please be sure to observe instructions from the motor manufacturer!

L External conductor
N Neutral conductor

5.3 Electrical connections three-phase current

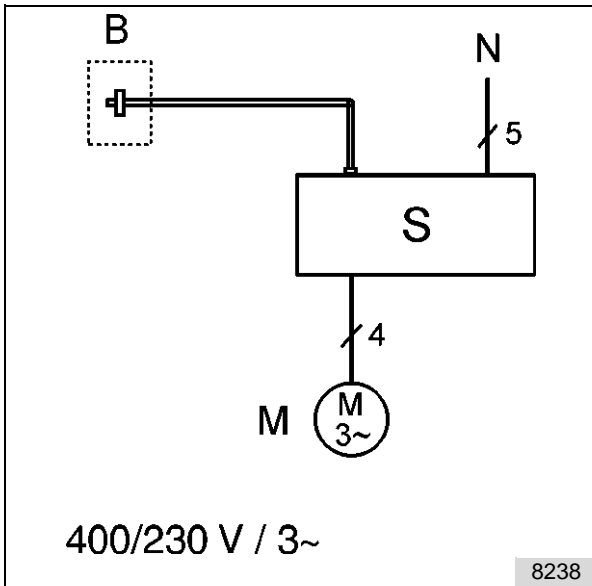

fig. 28: Basic circuit diagram for 400/230 V three-phase current

Mains voltage: 400/230 V for 3 ~ current

Mains power supply connection cable: 5 x 2.5 mm²

Pump power supply cable: 4 x 2.5 mm²

Fuse: 16A passive

B = Control unit in the pool

M = Motor of the circulation pump

N = Mains power supply (400/230 V 3 ~)

S = Switchgear cabinet

Connection cable, for example, HO7RNF, all further details required for making connections can be found in chapter 3.1.

Protective measures:

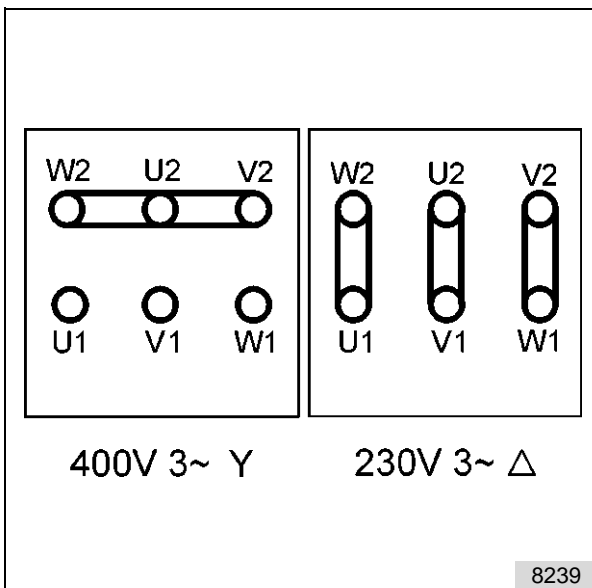

fig. 29: Basic circuit diagram for 400/230 V three-phase current



An earth leakage circuit breaker (nominal fault current ≤30 mA) must be fitted to the mains power supply!



Important: Watch the order of the terminal bridges!

See the inside of the terminal box lid or enclosed circuit diagram. Please be sure to observe instructions from the motor manufacturer!

L External conductor

N Neutral conductor

6 Start-up / Operating

Never carry out a trial run with the motor as long as there is no water in the pump. A dry run will destroy the mechanical seal in the pump!

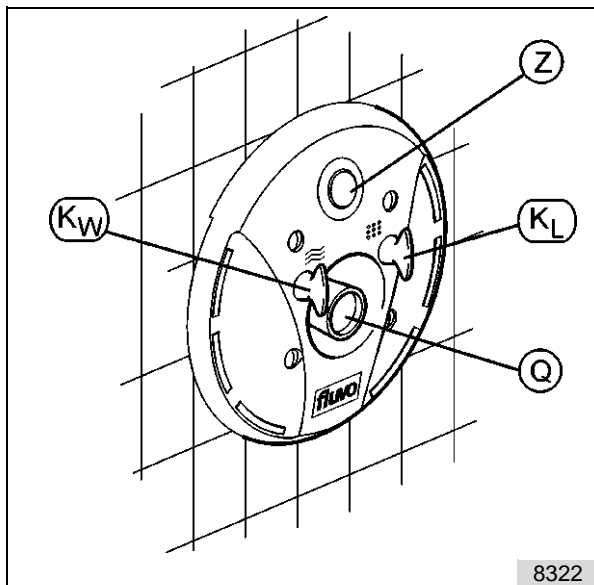

fig. 30

<i>K_L</i>	<i>Air supply regulator knob</i>
<i>K_W</i>	<i>Water supply regulator knob</i>
<i>Q</i>	<i>Nozzle</i>
<i>Z</i>	<i>Switching button</i>

- **Switching the pump on and off**

The pump is switched on by pressing the switching button (Z). After 2 seconds the pump can be switched off by pressing the button again or a signal can be sent to the pump (on-off function).

- **Water supply control**

By turning the knob (K_W) clockwise the water supply decreases, anti-clockwise it increases.

- **Air supply control / Air bubble bath**

By turning the knob (K_L) clockwise the air supply decreases, anti-clockwise it increases. The air supply to the water causes the water jet to become softer (air bubble bath).

- **Direction of jet**

The nozzle can be turned in any direction.

- **Counter-current swimming**

Set the maximum jet speed. Swing the nozzle (Q) so that the water layer just under the surface of the water begins to flow quickly.

- **Attaching the massage set**

Switch off the counter-current swimming unit prior to attaching the impulse-massage nozzle.

Pull back the sliding sleeve (V), push the hose coupling (F) into the nozzle (D), press the sliding sleeve (V) against the nozzle (D) and pull back on the hose coupling (F). That causes the hose coupling to be locked in place

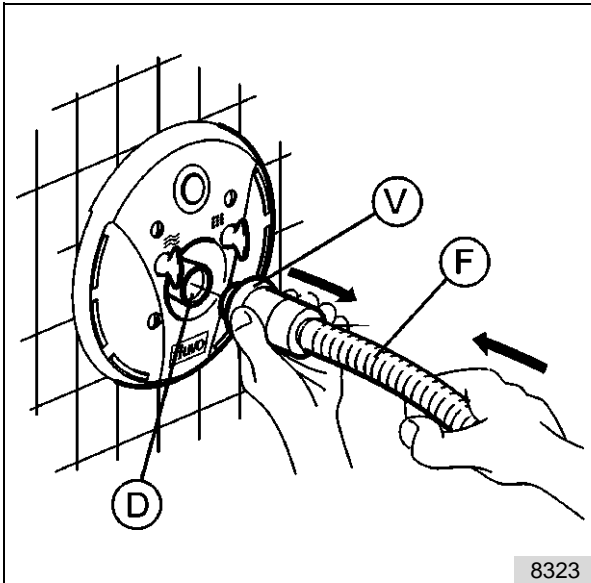

fig. 31: Attaching the massage set

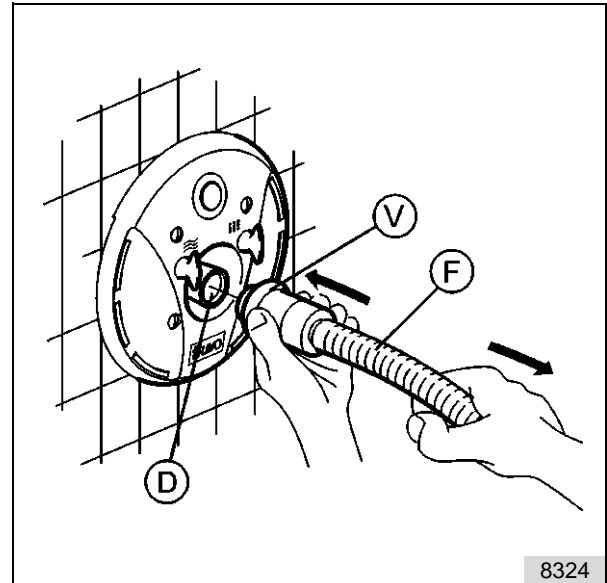

fig. 32: Detaching the massage set

D Nozzle
F Hose coupling

V Sliding sleeve

- **Detaching the massage set**

Switch off the counter-current swimming unit prior to detaching the impulse-massage nozzle.

Press the hose coupling (F) against the sliding sleeve (V), take a hold of it and pull it back, pull out the hose coupling.

7 Fault Assistance



Warning!

In accordance with UVV (Accident Prevention Regulations) all repairs and intervention to the unit must be carried out exclusively by qualified persons otherwise damage (accidents) could result to the user / operator.

The functional faults listed in the table are the most frequent causes of defects. If the corrective measures described are not successful, then the specialist that is called in individual cases will have to investigate the cause of the fault.

Functional fault	Possible cause	Remedy
1. Pump runs very loudly and lacks performance	Motor rotating in the wrong direction	Re-pole the motor in the terminal box and reverse the direction
	Motor blower brushes against the blower cover	Fasten the blower cover properly
2. Pump starts up heavily and slowly	A current phase is missing	Check supplies and fuses
3. The fuses jump out when the pump is switched on	Wrong or too nimble fuses	Insert passive fuses with the correct current rating.
4. Motor protection switch trips	Wrong setting	Set correct current value +10% (see Technical Data)
5. Centrifugal pump cannot be switched on from the pool	<ul style="list-style-type: none"> - Switching tube has a kink in it - Fuse / power supply - Motor protection switch - Switching tube too long - Water in the switching tube 	Check whether centrifugal pump can be switched from the switchgear box. - Eliminate causes in accordance with chapter 4 . Shorten switching tube, if possible. - Blow through the switching tube from the swimming pool end
6. Air valve leaks	dirty	Screw the air valve off and wash it out during normal operation. Replace it, if necessary. Note: The air valve must be located above the water surface.

8 Shutdown / Overwintering



Warning! Risk of damage!

If there is a risk of freezing, then the facility must be made winterproof. For this observe the following recommendations:

8.1 Empty the pool

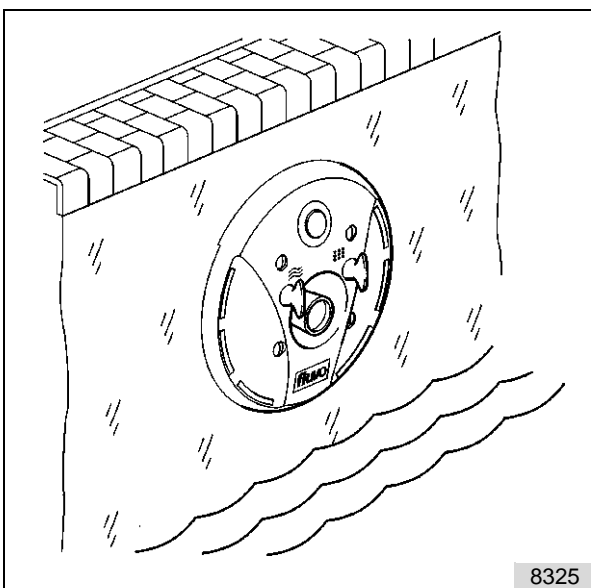

fig. 33



Warning! Risk of damage!

Make sure you have protected the whole swimming complex adequately against frost. Observe the instructions issued by the manufacturer of the pool!

- Empty all the water out of the pool,
- or let the water out at least until it is below the level of the jet head.
- Switch off the master switch!

8.2 Face plate assembly overwintering

Remove the face plate assembly and store at room temperature.

8.3 Draining the pump

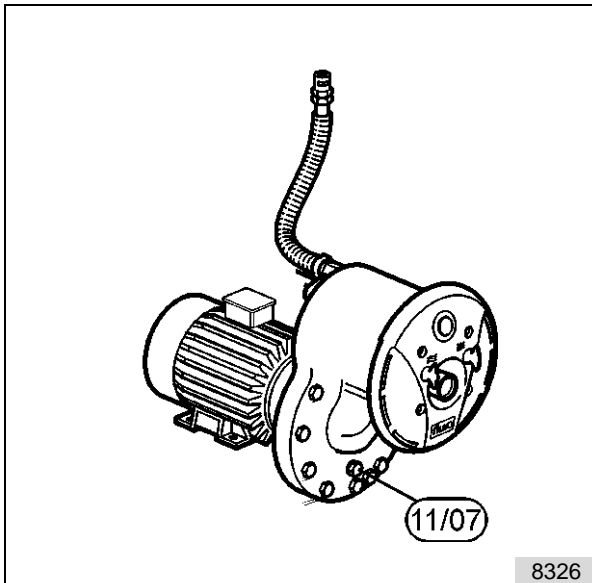

07 O-Ring

11 Plug screw

Screw out the plug screw (11) and drain the water.



Warning! Risk of damage!

Make sure that all the water runs off! Also drain the pipework connected to the pump, if any!

Then screw the plug screw (11) back in again with a new O-ring (07).

When restarting please observe the instructions in section 6.

fig. 34

9 Maintenance and Repair

9.1 General

All work on the counter-current unit must be carried out only if the pump has been drained and the control unit and pump motor have been disconnected from the mains and secured against unintentional reconnection.

9.2 Maintenance

- The counter-current unit is largely maintenance-free.
- Make sure that all the parts of the counter-current unit are kept clean.
- The gaskets on the motor shaft must be checked at regular intervals (at least once a year) by a trained engineer. If necessary, they must be replaced by original spare parts.

9.3 Repairs

- For miscellaneous repairs to the counter-current system please observe the instructions for installation and start-up in this manual.
- Use exclusively original spare parts when carrying out repairs to the counter-current unit.

10 Ersatzteilliste und Zeichnung

10.1 Ersatzteilliste

10 Spare Parts List and Drawing

10.1 Spare Parts List

Pos.	Best. Nr. No. de réf. Order No.	Bezeichnung	Description	Stck. Nbre. Qty.	Bemerkung Remarque Remark
01	365450	Wechselstrommotor	Motor 1-phase	1	1,9 kW IEC 38 230 V
01.1	363667	Drehstrommotor	Motor 3-phase	1	1,9 kW IEC 38 400 V
01.2	02440	Drehstrommotor	Motor 3-phase	1	3,0 kW IEC 38 400 V
02	89096	Schaltkasten Wechselstrom	Switchgear cabinet 1-phase	1	1,9 kW 230 V
02.1	89088	Schaltkasten Drehstrom	Switchgear cabinet 3-phase	1	1,9 kW 400 / 230 V
02.2	89125	Schaltkasten Drehstrom	Switchgear cabinet 3-phase	1	3 kW 400 / 230 V
03	R47505	Spiralgehäuse	Spiral housing	1	
04	21140	Gleitringsdichtung	Mechanical seal	1	
05	51066	Unterlegscheibe	Distance washer	1	
06	51021	Lauftrad	Impeller	1	1,9 kW Ø 110
06.1	51022	Lauftrad	Impeller	1	3,0 kW Ø 125
07	24133	O-Ring	O-ring	2	10,0 x 2,0
08	56033	Lauftradschraube	Impeller cap screw	1	
09	22113	Flachdichtung	Clamp Gasket	1	
10	56121	Ansauggehäuse	Suction housing	1	
11	11104	Verschluss-Schraube	Plug screw	2	G1/4"
12	56122	Druckrohr	Pressure pipe	1	
14	59070	Halterung	Holding device	1	
15	10469	Sechskantschraube	Hexagon screw	2	M6 x 25
17	23082	Dichtung	Gasket	1	
18	28022	O-Ring	O-ring	1	
20	93115	Einbausatz	Installation kit	1	
21	92195	Schlauchkupplung	Hose coupling	1	
22	45161	Klemmring	Clamp ring	1	

Pos.	Best. Nr. No. de réf. Order No.	Bezeichnung	Description	Stck. Nbre. Qty.	Bemerkung Remarque Remark
23	12424	Unterlegscheibe	Distance washer	1	Ø 8
24	12422	Unterlegscheibe	Distance washer	9	A 8
25	10587	Sechskantschraube	Hexagon screw	10	M8 x 55
26	12181	Sechskantmutter	Hexagon nut	15	M8
27	12392	Unterlegscheibe	Distance washer	15	A 8
28	56031	Rückschlagventil	Non-return valve	1	
29	63127	Übergangsnippel	Air line hose tail	1	incl. Pos. 33
29.1	56128	Schlauchkupplung	Hose coupling	1	
30	48456	Klemmring	Clamp ring	1	
31	16220	Schalterschlauch	Switching tube	1	
32	22235	Flachdichtung	Clamp gasket	1	200x150x2,0
33	63338	Tülle	Hose tail	1	
35	92192	Düsenkopf	Face plate assembly	1	
35.1	92199	Düsenkopf	Face plate assembly	1	
36	65032	Drehgriff Luftreg.	Air regul. knob	1	
37	65033	Drehgriff Wasserreg.	Water flow knob	1	
38	56232	Düsengehäuse	Face plate	1	
39	22227	Flachdichtung	Clamp gasket	1	250x198x2,0
39.1	22226	Flachdichtung	Clamp gasket	1	250x150x2,0
40	56035	Düse	Nozzle	1	
41	56050	Kugelgleitring	Nozzle clamp seal	1	
42	15103	Druckfeder	Pressure spring	4	
43	56036	Gehäuse	Housing	1	
43.1	10401	Schneidschraube	Socket head cap screw	3	5,5 x 25
44	13154	Zylinderstift	Parallel pin	1	
45	55602	Welle f. Luftregelung	Air regulator shaft	1	
46	22008	Flachdichtung	Clamp gasket	1	16x08x3,0
47	56068	Bundhülse	Shaft collar	1	
48	57952	Zentrierhülse	Nozzle case sleeve	1	
48.1	56069	Zentrierhülse	Nozzle case sleeve	1	
49	56682	Gewindehülse	Threaded sleeve	1	
50	23073	Dichtung	Gasket	2	
51	56681	Gleitmutter	Regulator nut	1	
52	16068	Schlauchselle	Air pipe clamp	1	
53	56070	Drosselklappe	Regulating flap	1	
54	13226	Zylinderkerbstift	Locking pin	1	
55	56680	Verstellspindel	Water regulator shaft	1	
56	67122	Befestigungssatz Luftventil	Fixing bracket for air valve	1	
57	10561	Sechskantschraube	Hexagon screw	1	M8 x 30

Pos.	Best. Nr. No. de réf. Order No.	Bezeichnung		Description	Stck. Nbre. Qty.	Bemerkung Remarque Remark
58	55272	Befestigungsschelle		Clamp	1	
59	67005	Spreizdübel		Rawl plug	1	SD 8
60	60045	Luftventil		Non-return air valve	1	
61	10244	Blehschraube		Tapping screw	3	4,2x13
62	56229	Haltering		Hold-ring	1	204x155x4
63	10626	Senkschraube		Counter-sunk screw	7	M10 x 70
64	12392	Unterlegscheibe		Distance washer	7	A 10
64.1	12192	Sechskantmutter		Hexagon nut	7	M 10
65	92088	Luftleitung		Air hose	1	
66	93117	Anbauteile		Adaptor kit	1	
67	51303	Haltering		Hold-ring	1	
68	56241	Klemmring		Clamp ring	1	
76	65072	Einschubsatz		Insert set	1	
77	93118	Anbauteile		Adaptor kit	1	
84	12181	Sechskantmutter		Hexagon nut	8	M 8
85	12392	Unterlegscheibe		Distance washer	8	A 8
90	10539	Linsensenkschraube		Face plate screw	4	M8x45
90.1	10880	Linsensenkschraube		Face plate screw	4	M8x100
90.2	10779	Linsensenkschraube		Face plate screw	4	M8 x 70
90.3	10539	Linsensenkschraube		Face plate screw	4	M8x45
96	55539	Abstandshülse		Distance washer	1	
97	24424	V-Ring		V-ring	1	
98	22213	Flachdichtung		Clamp Gasket	1	

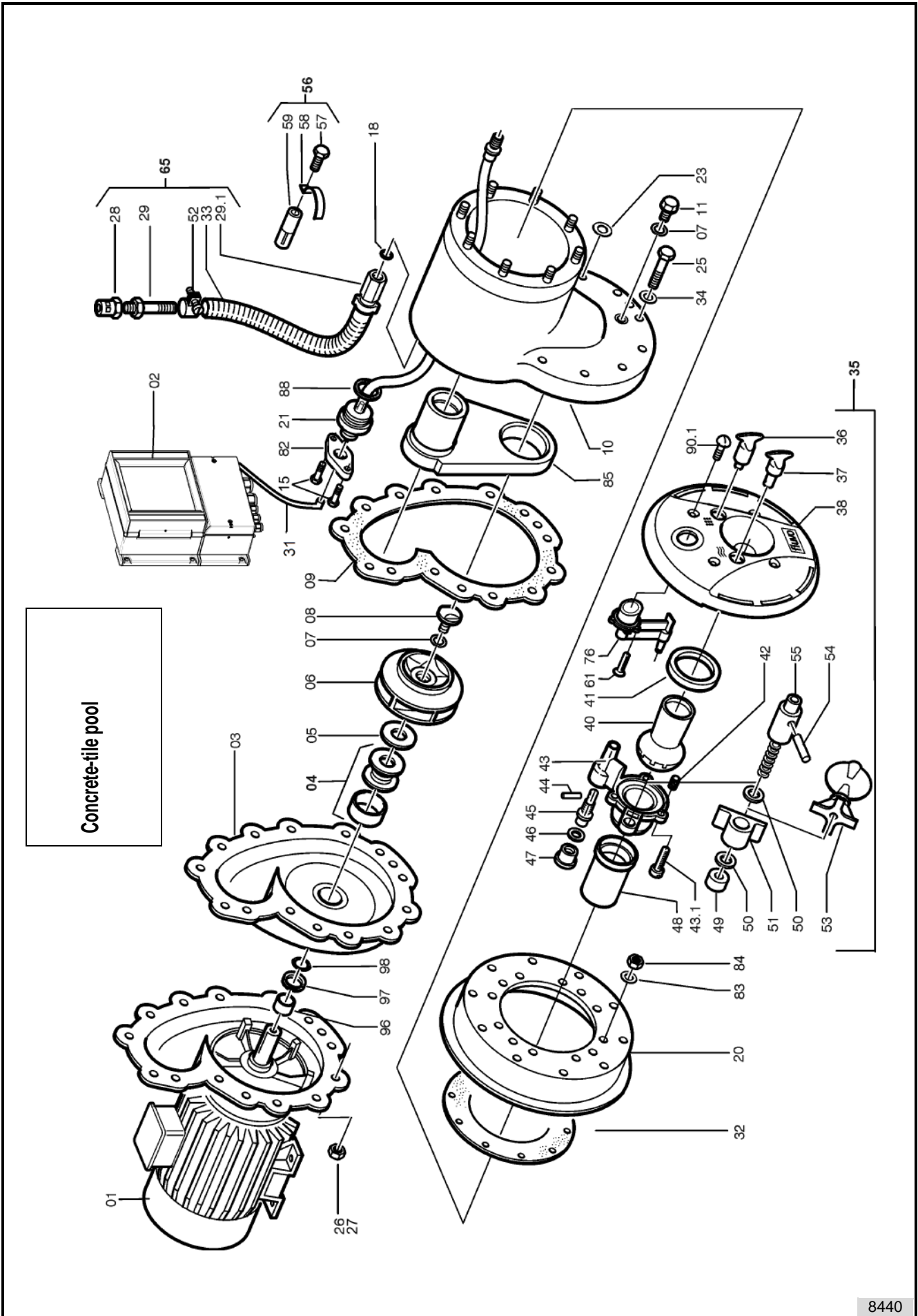

8440

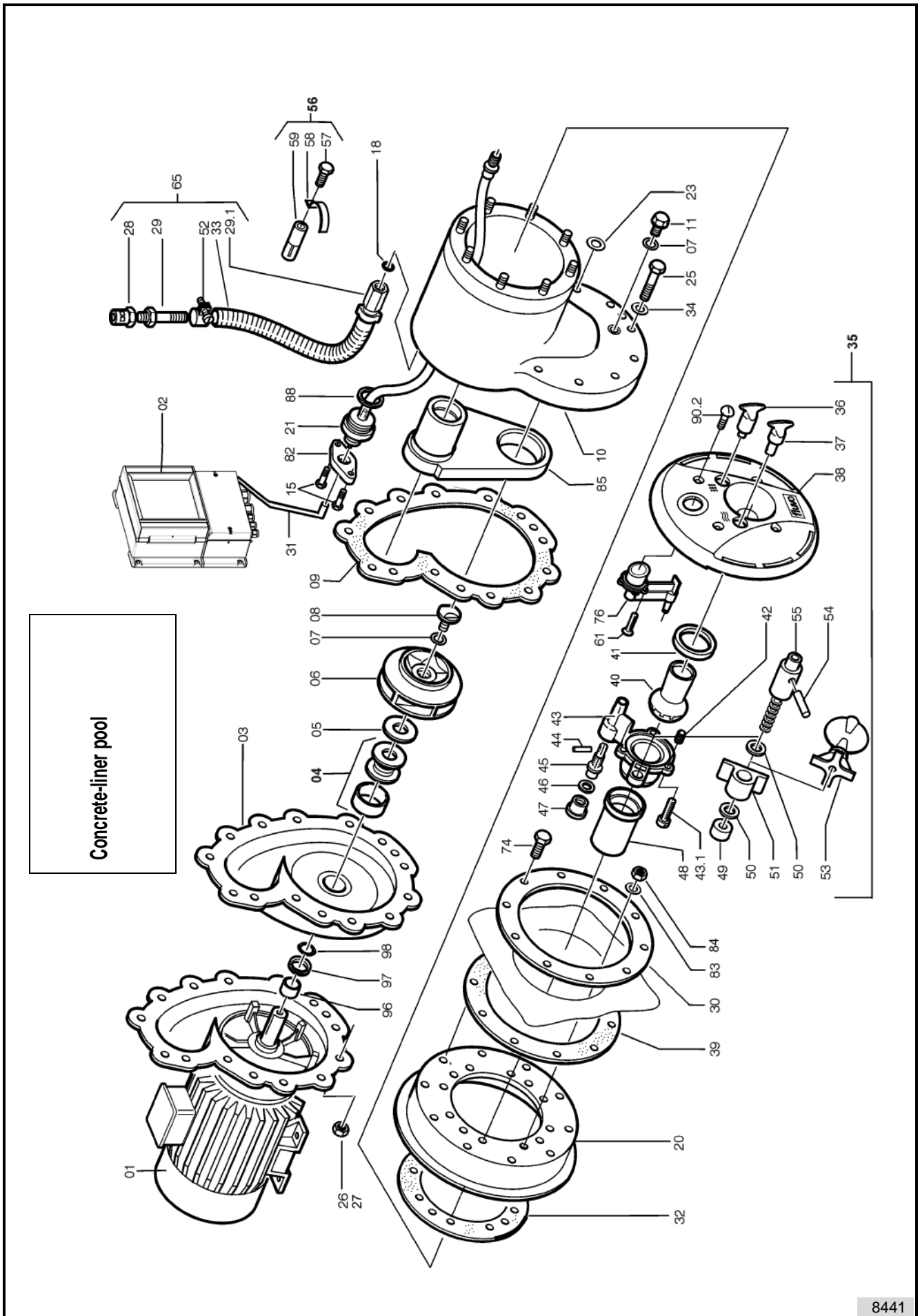

8441

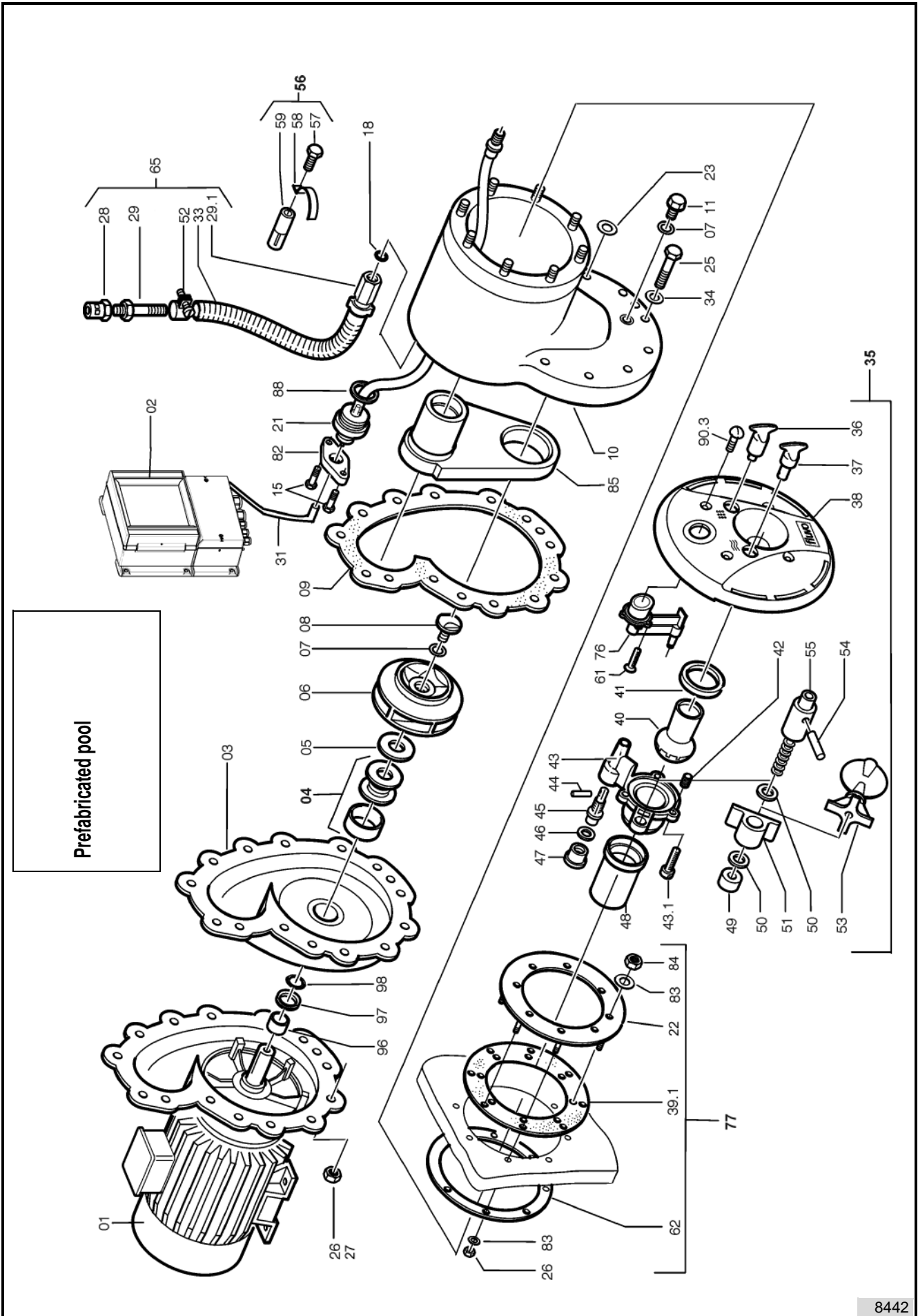

8442

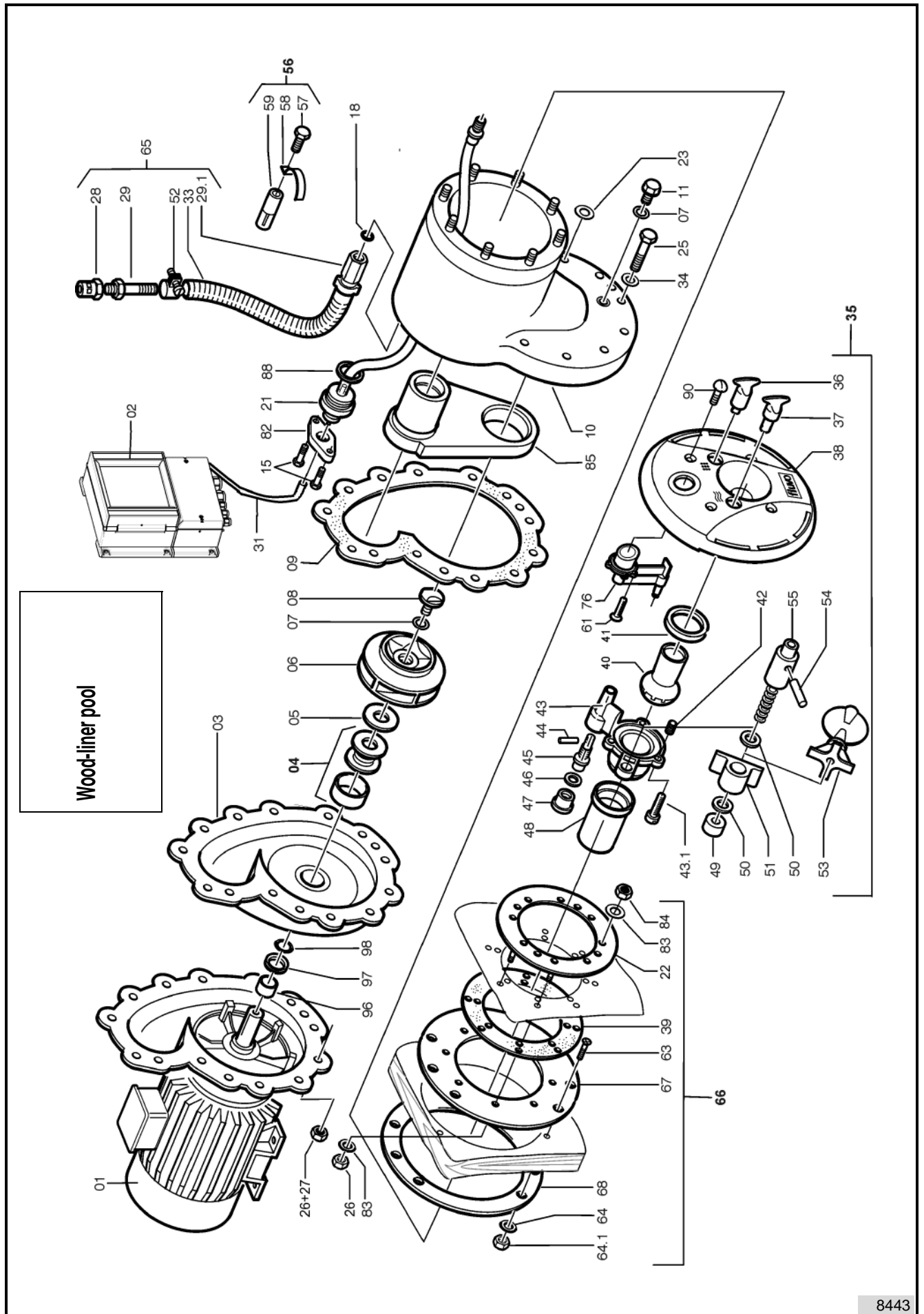

8443



Importer:
Certikin International Ltd
4 Tungsten Park
Colletts Way
Witney
Oxfordshire, OX29 0AZ
United Kingdom
www.certikin.co.uk

Manufacturer:
Schmalenberger GmbH + Co. KG
Strömungstechnologie
Im Schelmen 9 - 11
D-72072 Tübingen / Germany

Telefon: +49 (0)7071 70 08 - 0+49
Telefax: (0)7071 70 08 - 10
Internet: www.fluvo.de
E-Mail: info@schmalenberger.de

© 2022 Schmalenberger GmbH + Co. KG ; All rights reserved
This document is subject to change without notice